



# Clarifying design guidelines of level crossing logic with functional resonance analysis method

22nd October 2019

East Japan Railway Company

A. Okada, S. Kitamura and T. Kunifuji

Japan manned Space Systems Corporation

K. Sakemi and H. Nomoto

- Introduction of East Japan Railway Company (JRE)
- Motivation
- Functional resonance analysis method
- Basic warning logic of level crossings
- Analysis of one standardized level crossing logic and extraction of design guidelines
- Evaluation with operating LC logic
- Conclusion

# Introduction of JRE

Operating area: East Japan including Tokyo

Passengers : over 17 million / day

Rail network: 7,401.7 km

Station: 1,655

Interlocking system : 967

Point machine : 9,760

Signal : 12,409

Level crossing (LC) : 6,774

as of Mar. 2019

([https://www.jreast.co.jp/youran/pdf/2019-2020/jre\\_youran\\_all.pdf](https://www.jreast.co.jp/youran/pdf/2019-2020/jre_youran_all.pdf))



# Two types of level crossings

## Level crossing (LC) between stations

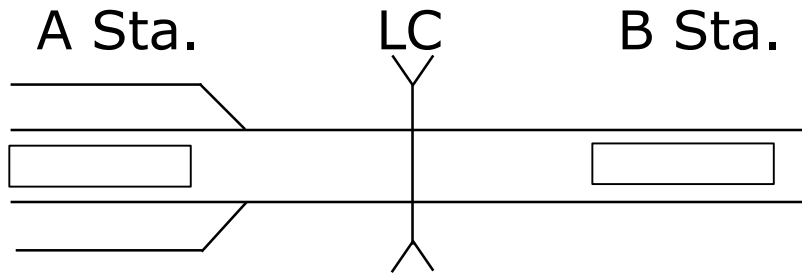

- Simple and common logic
- Software logic

## LC in a station and a yard

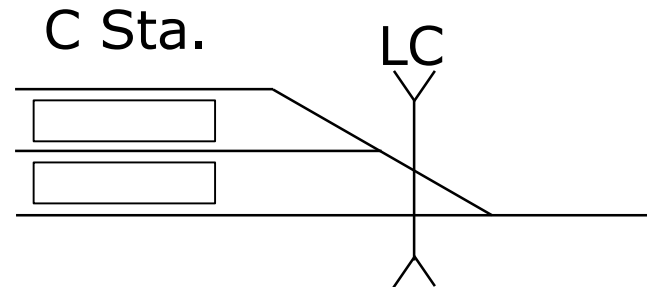

- Complex and LC-specific logic
- Relay logic

Developing software logic for LC in a station can improve maintainability and workability but is not easy



# Functional Resonance Analysis Method (FRAM)

- Safety-analysis method from resilience engineering
- Modelling interactions among functions by using hexagonal elements with six aspects
- FRAM Model helps to extract how a system works or why a system successes and fails

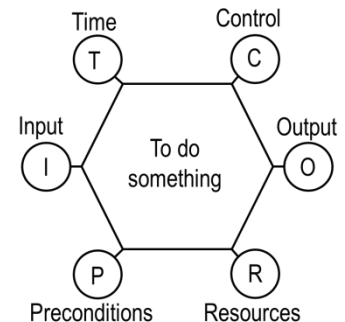

- Simple example of a FRAM model
  - The model that information of train detection at A is used to start warning of a LC

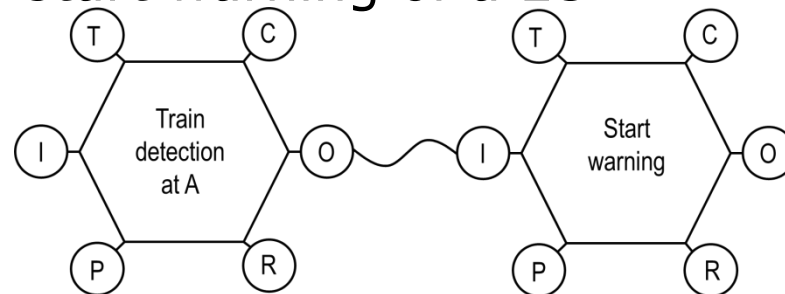

We examined FRAM to extract the design guidelines from standardized relay logic

# Sequence of basic warning logic

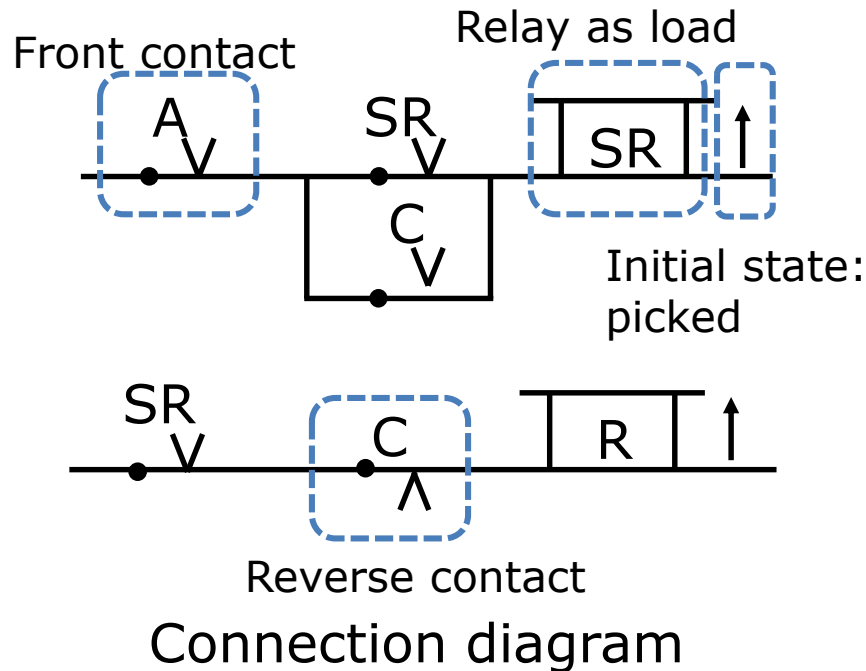
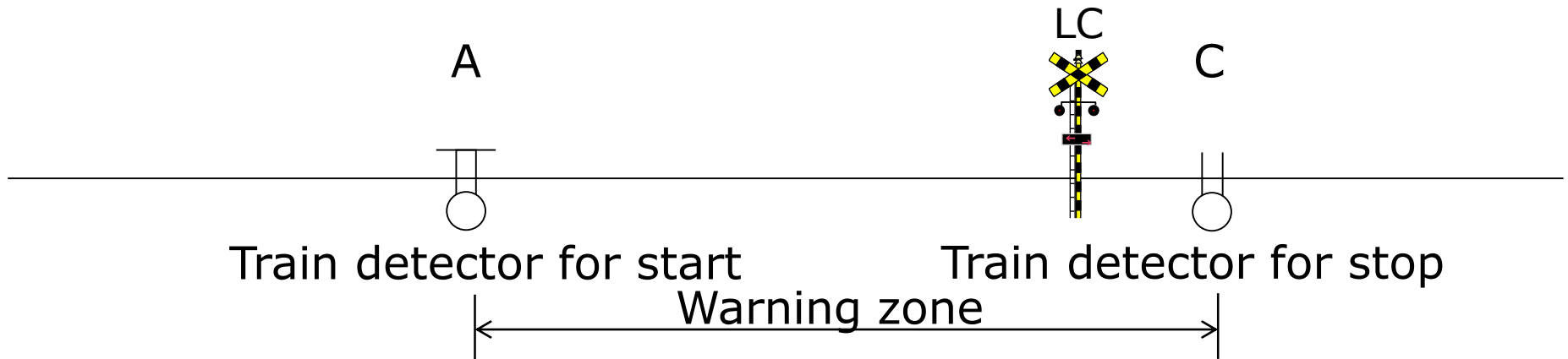

## Start warning

- (1) Detection of a train at A
- (2) Change of SR's state to "dropped"
- (3) Change of R's state to "dropped"

## Stop warning

- (1) Exit from train detection area of A
- (2) Detection of a train at C
- (3) Change of SR's state to "picked"
- (4) Exit from train detection area of C
- (5) Change of R's state to "picked"

# Sequence of basic warning logic

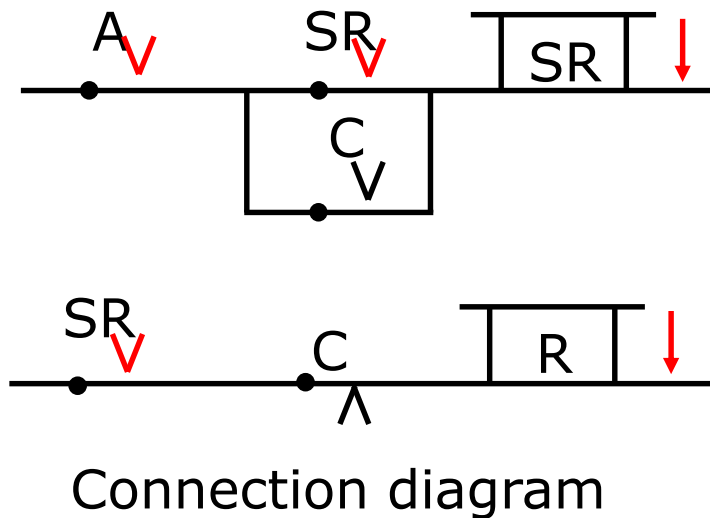
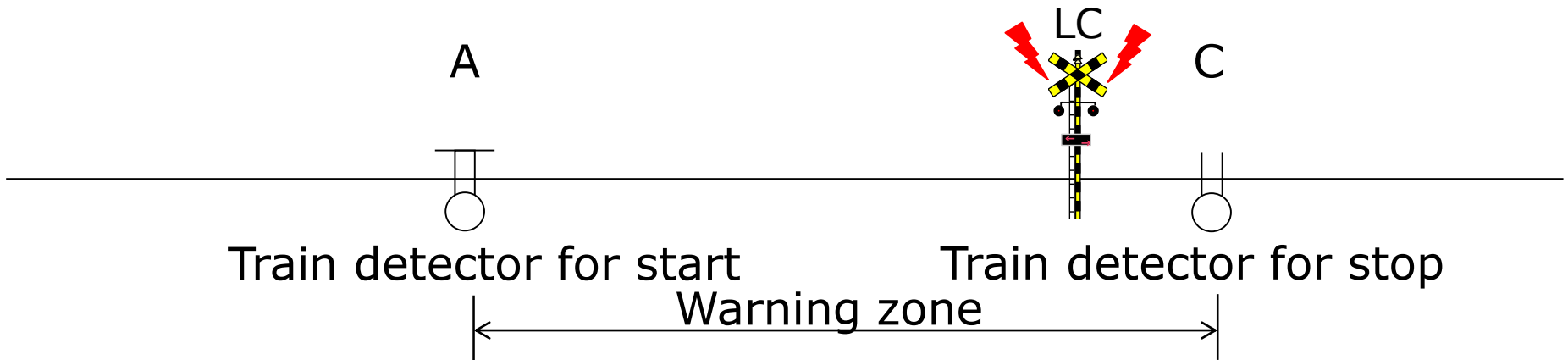

## Start warning

- (1) Detection of a train at A
- (2) Change of SR's status to "dropped"
- (3) Change of R's status to "dropped"

## Stop warning

- (1) Exit from train detection area of A
- (2) Detection of a train at C
- (3) Change of SR's status to "picked"
- (4) Exit from train detection area of C
- (5) Change of R's status to "picked"

# Sequence of basic warning logic

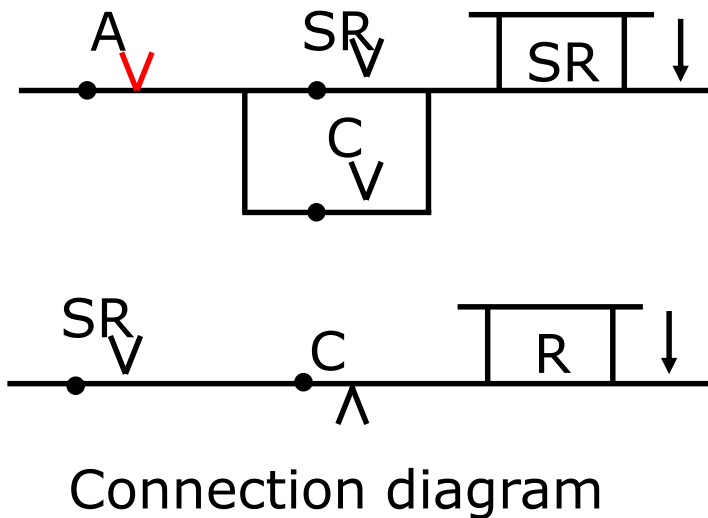
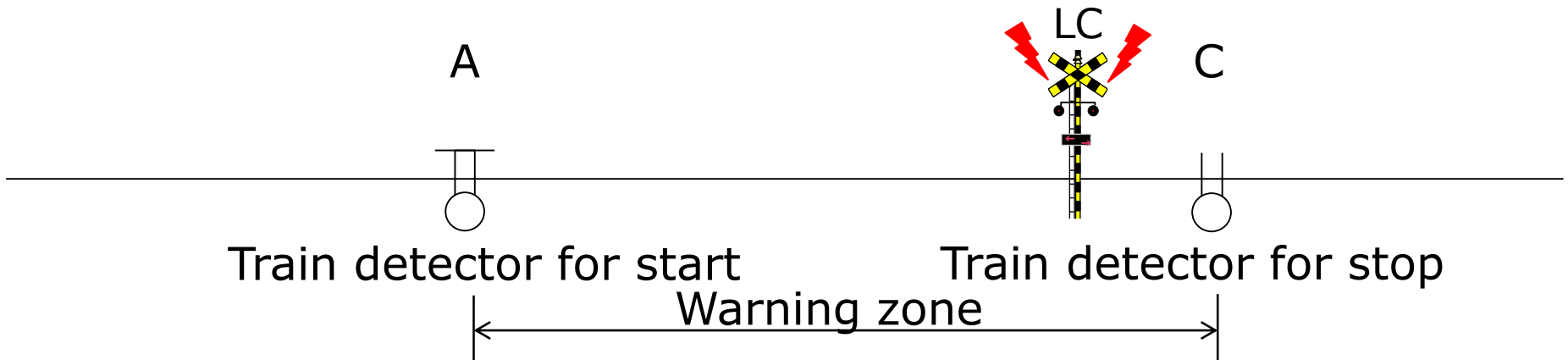

## Start warning

- (1) Detection of a train at A
- (2) Change of SR's status to "dropped"
- (3) Change of R's status to "dropped"

## Stop warning

- (1) Exit from train detection area of A
- (2) Detection of a train at C
- (3) Change of SR's status to "picked"
- (4) Exit from train detection area of C
- (5) Change of R's status to "picked"

# Sequence of basic warning logic

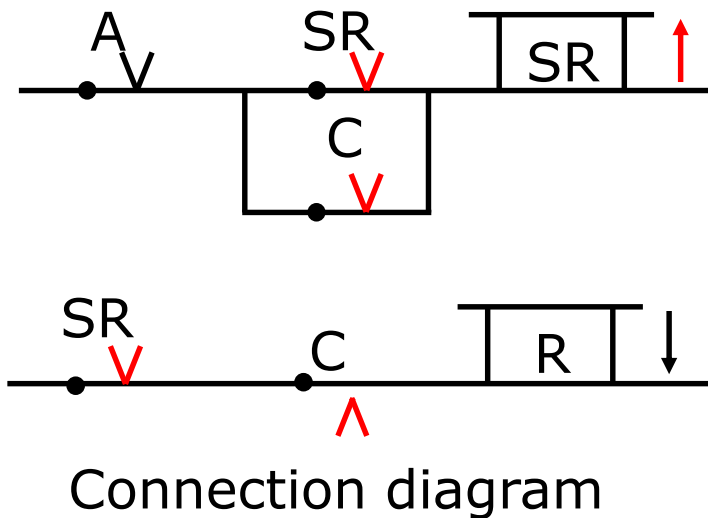
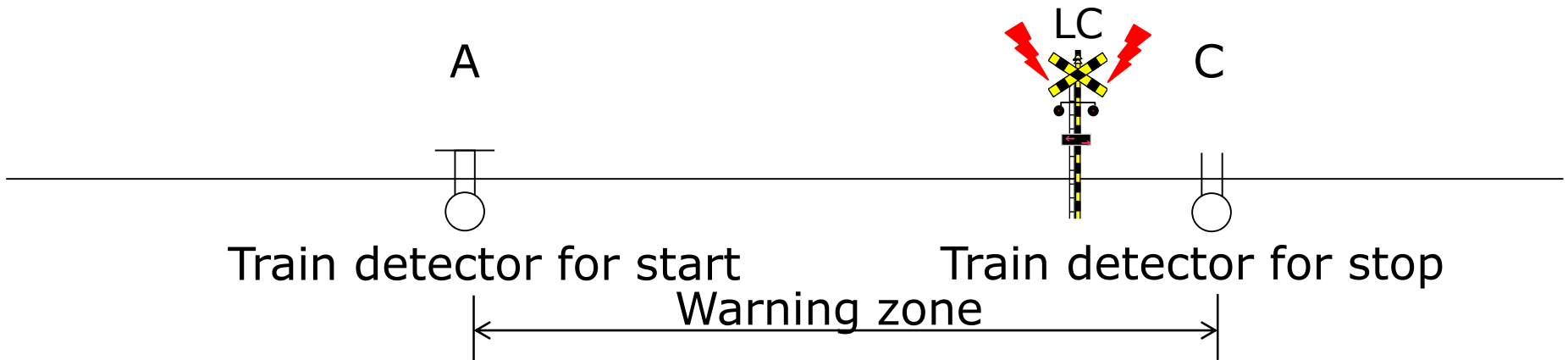

## Start warning

- (1) Detection of a train at A
- (2) Change of SR's status to "dropped"
- (3) Change of R's status to "dropped"

## Stop warning

- (1) Exit from train detection area of A
- (2) Detection of a train at C
- (3) Change of SR's status to "picked"
- (4) Exit from train detection area of C
- (5) Change of R's status to "picked"

# Sequence of basic warning logic

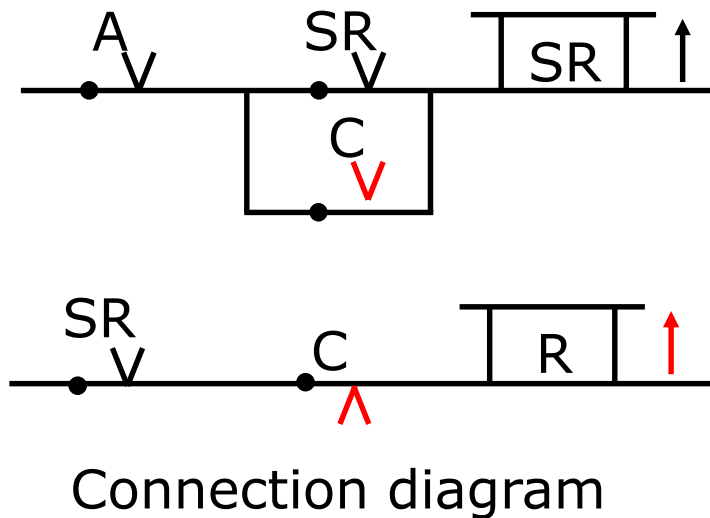
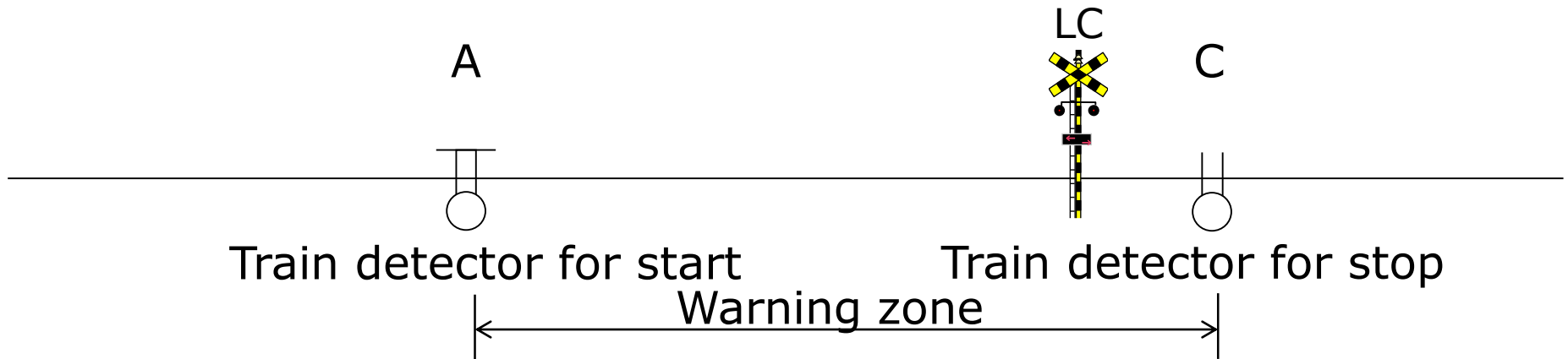

## Start warning

- (1) Detection of a train at A
- (2) Change of SR's status to "dropped"
- (3) Change of R's status to "dropped"

## Stop warning

- (1) Exit from train detection area of A
- (2) Detection of a train at C
- (3) Change of SR's status to "picked"
- (4) Exit from train detection area of C
- (5) Change of R's status to "picked"

Connection diagram

# Analysis of standardized logic

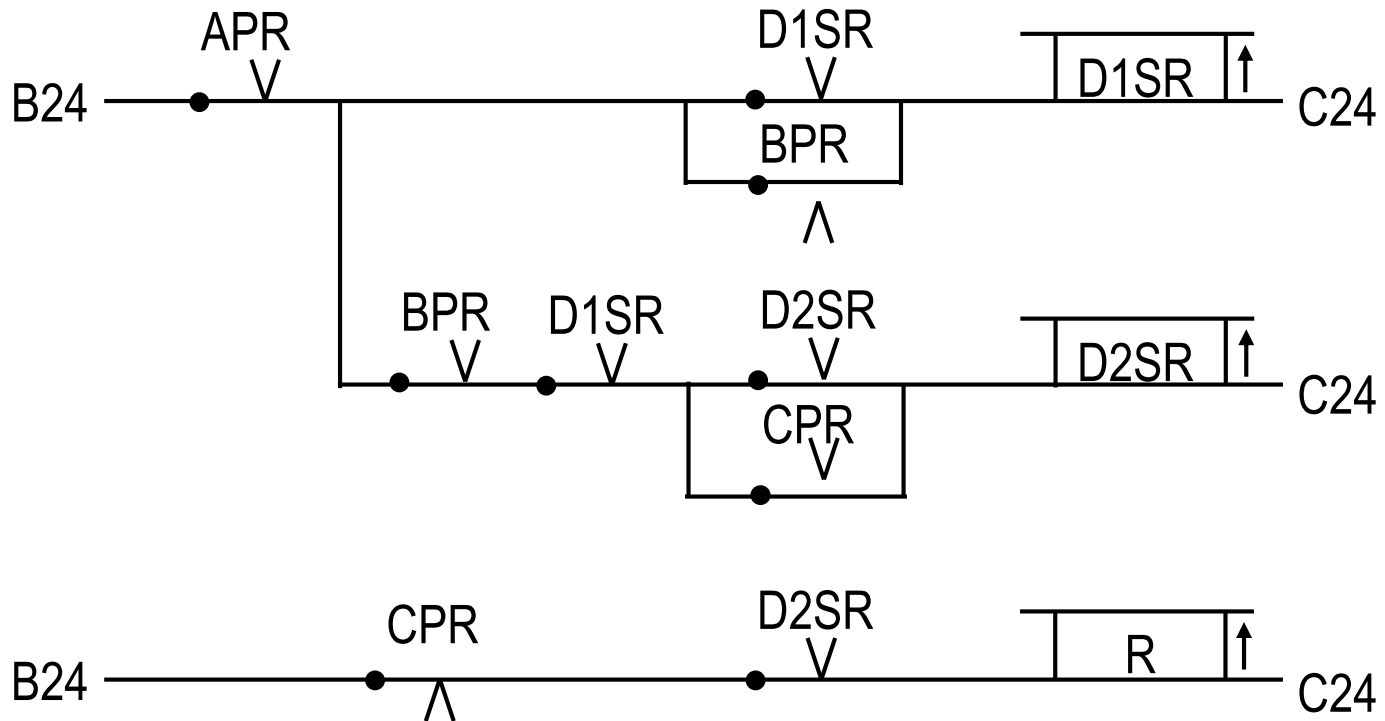
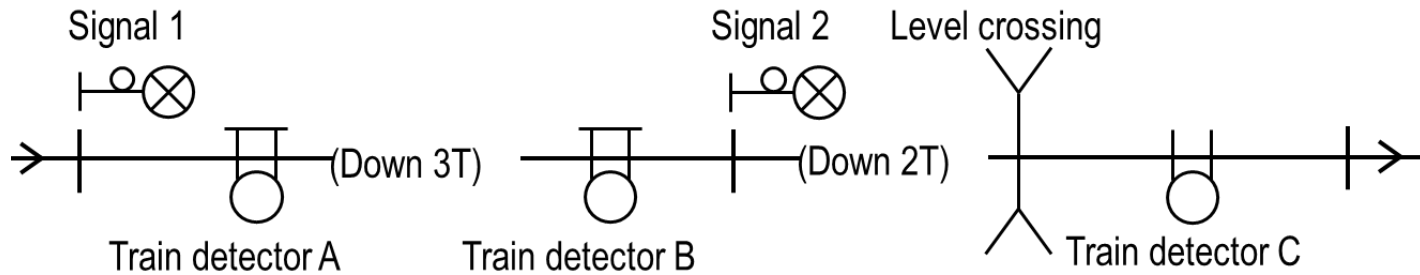

# Functional difference between the basic logic and the analyzed standard logic

Train detector B is deployed so that two trains can run within the warning zone in the same time.

Without B

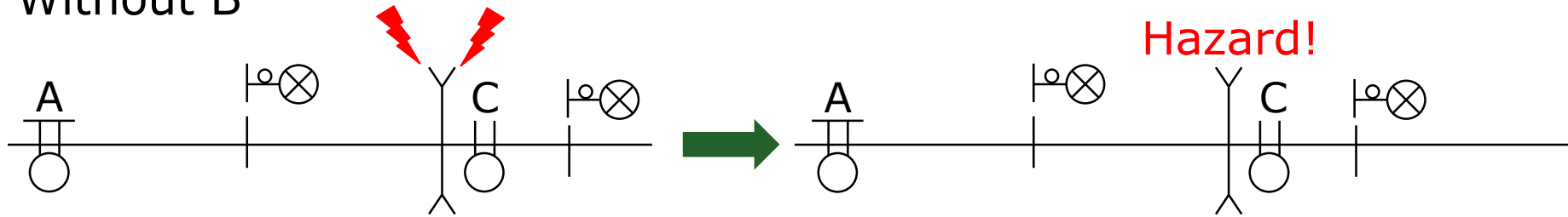

With B

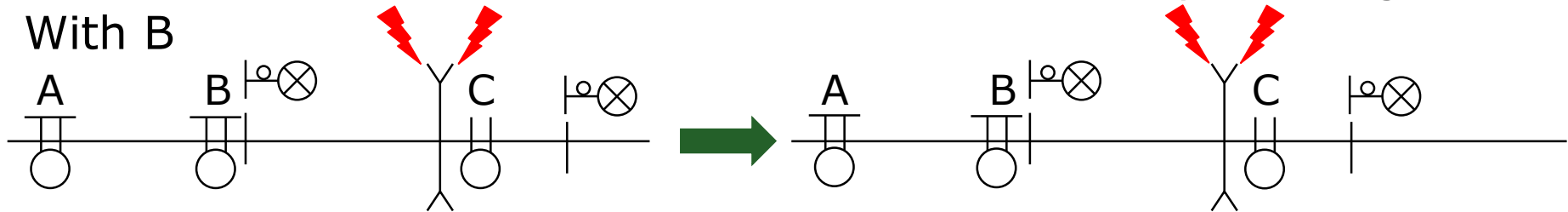

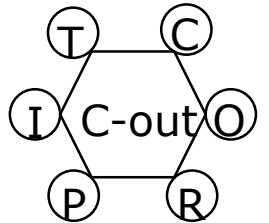
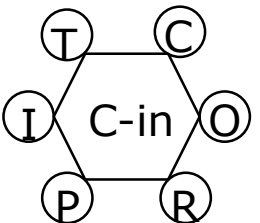
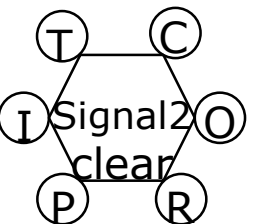
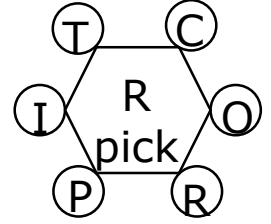
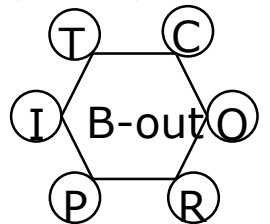
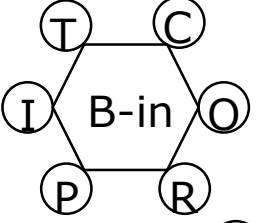
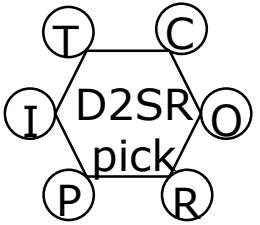
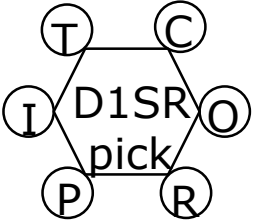
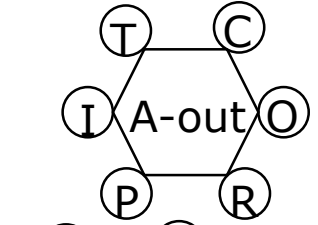
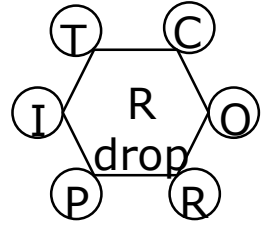
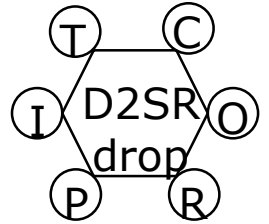
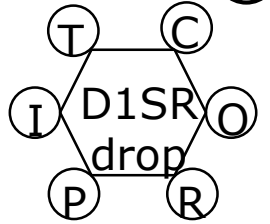
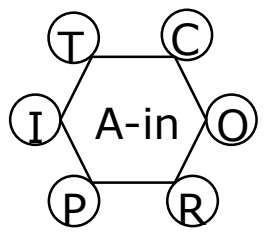
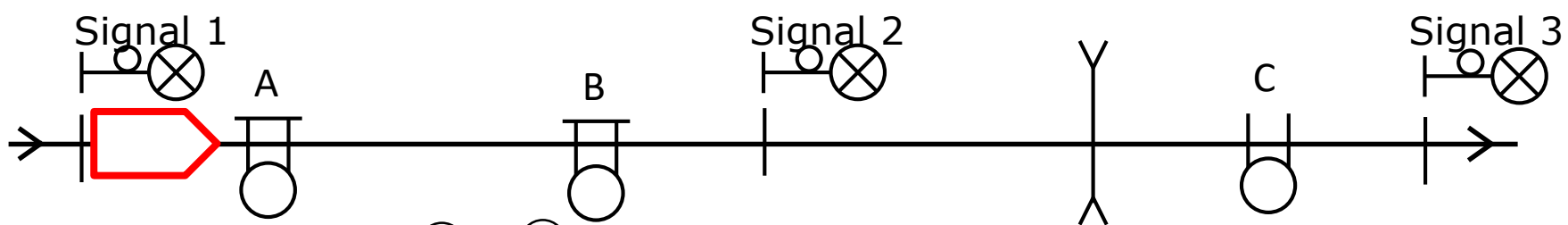

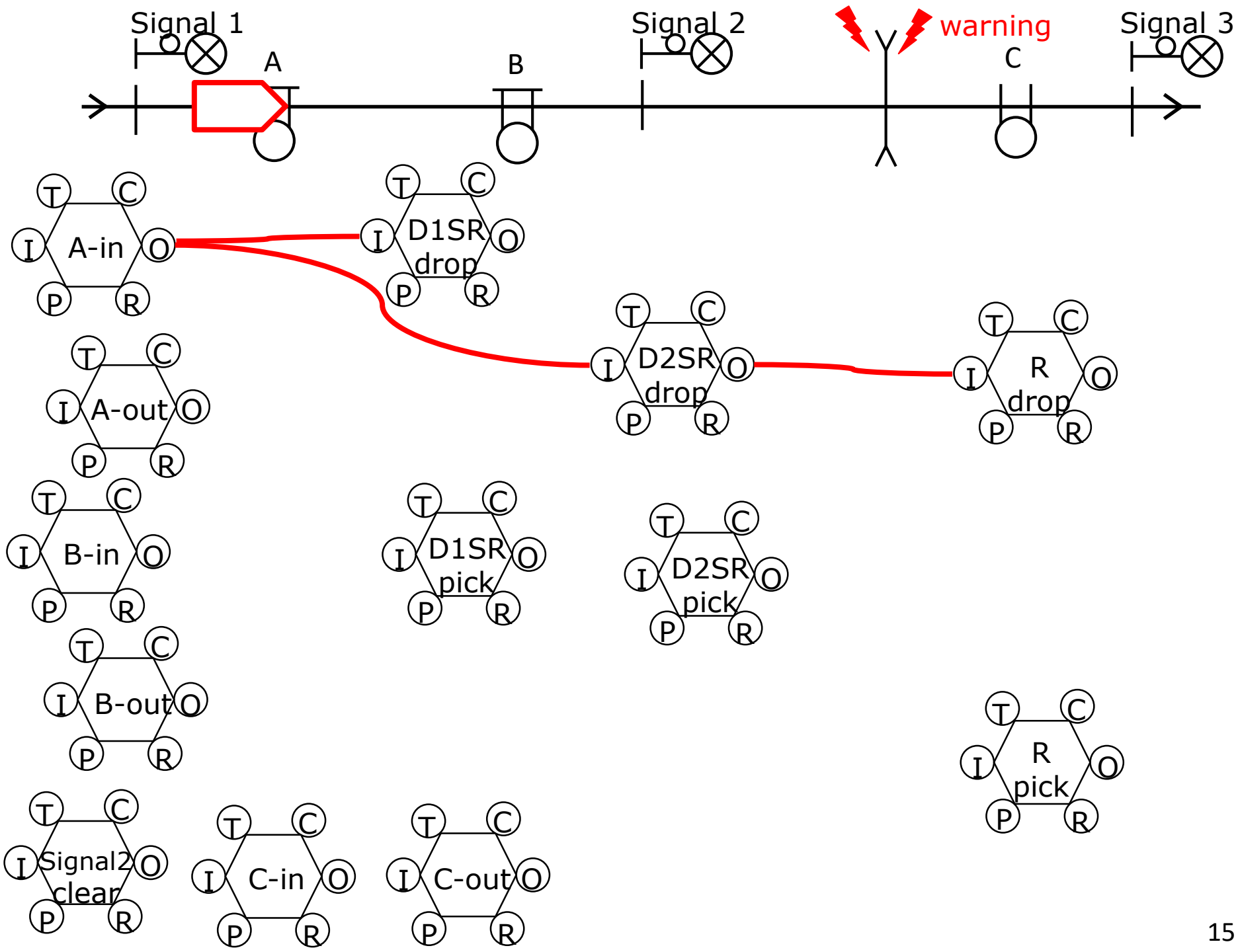

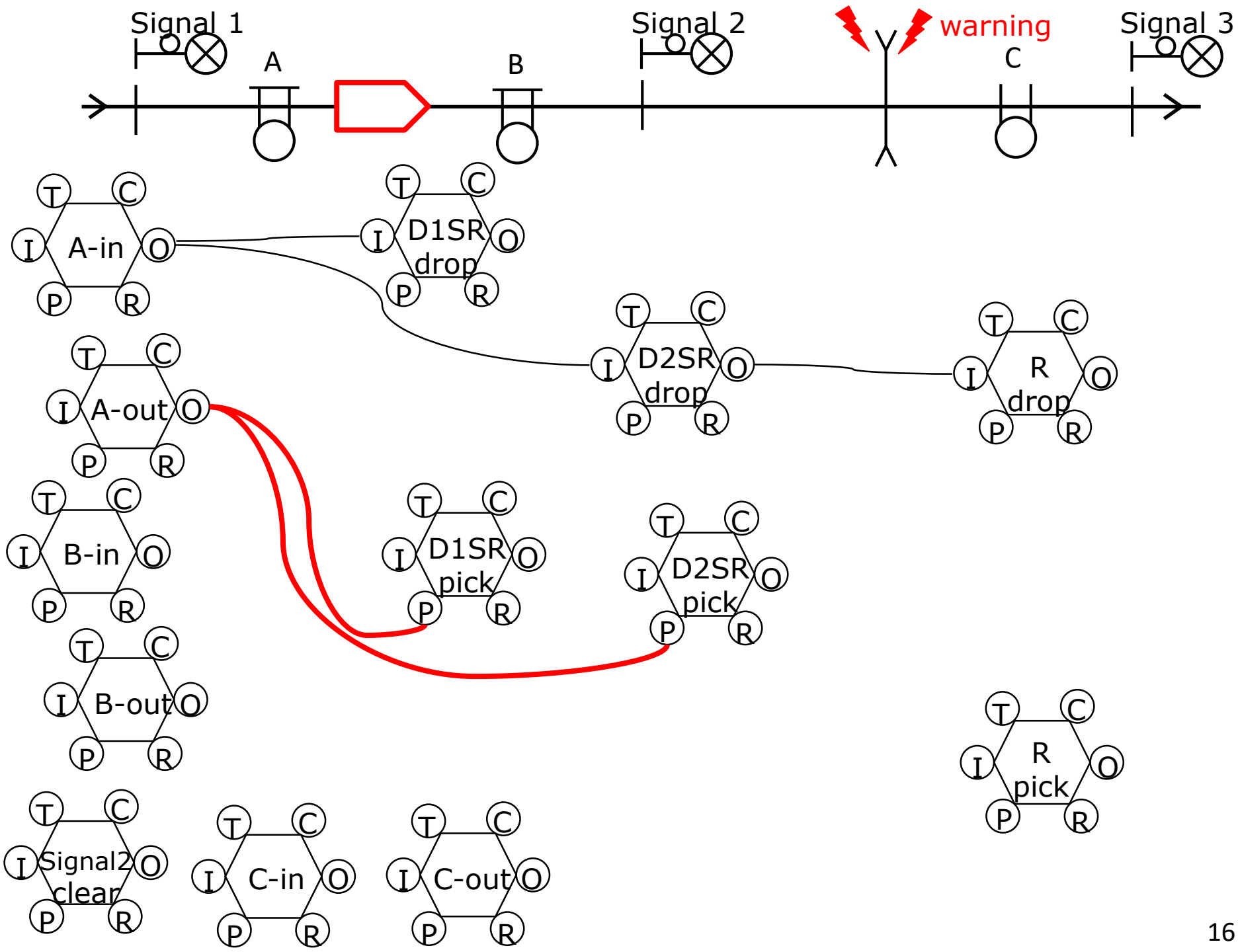

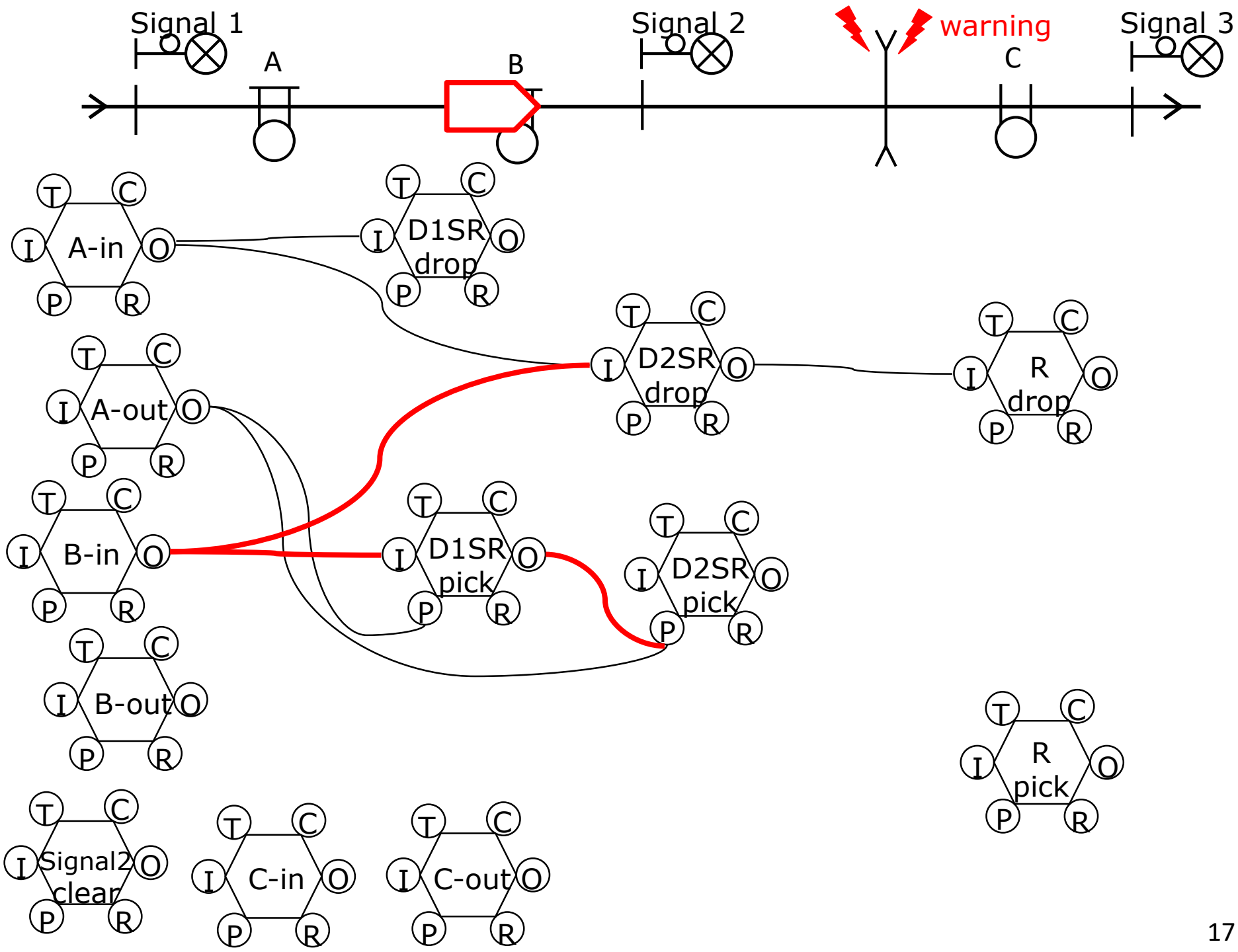

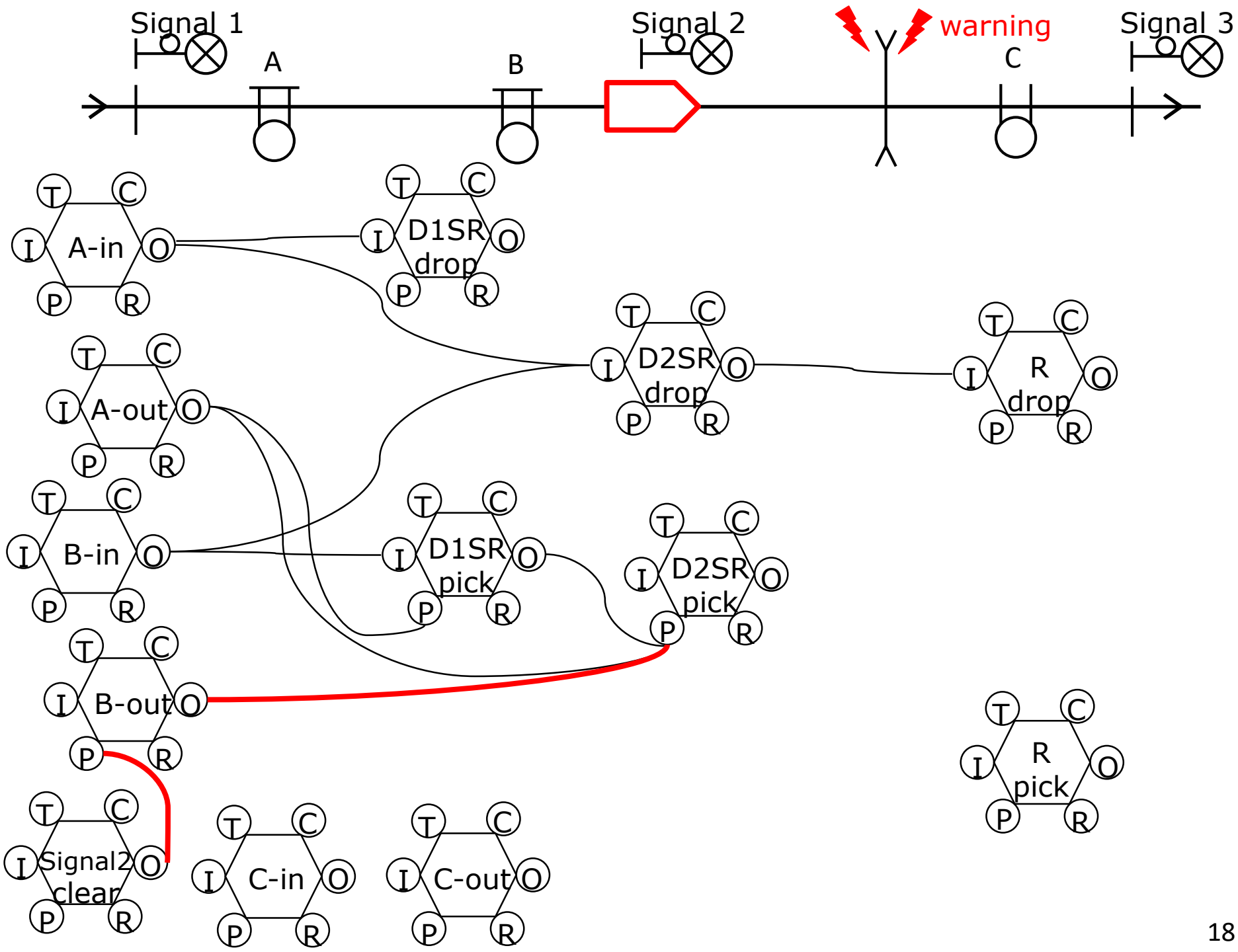

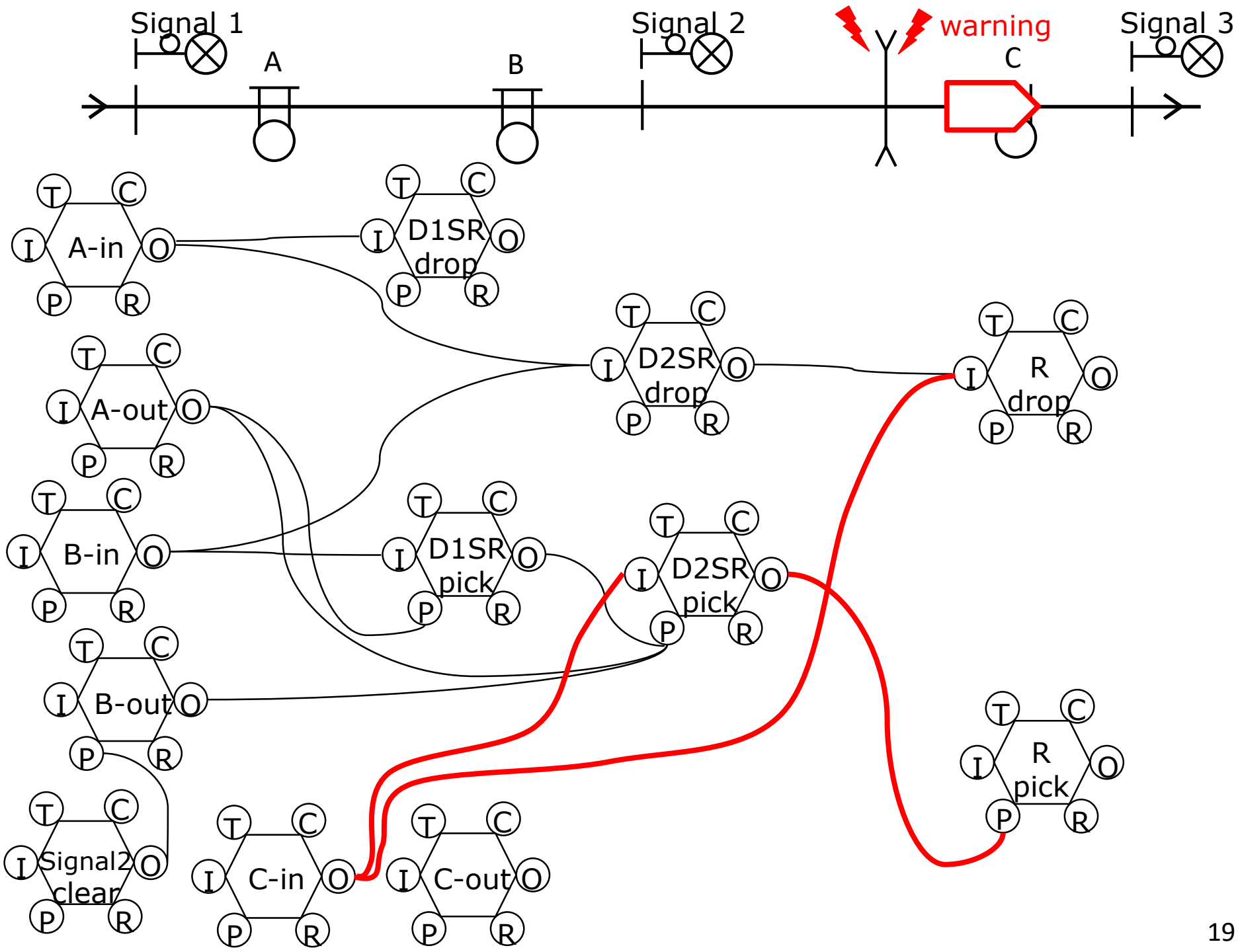

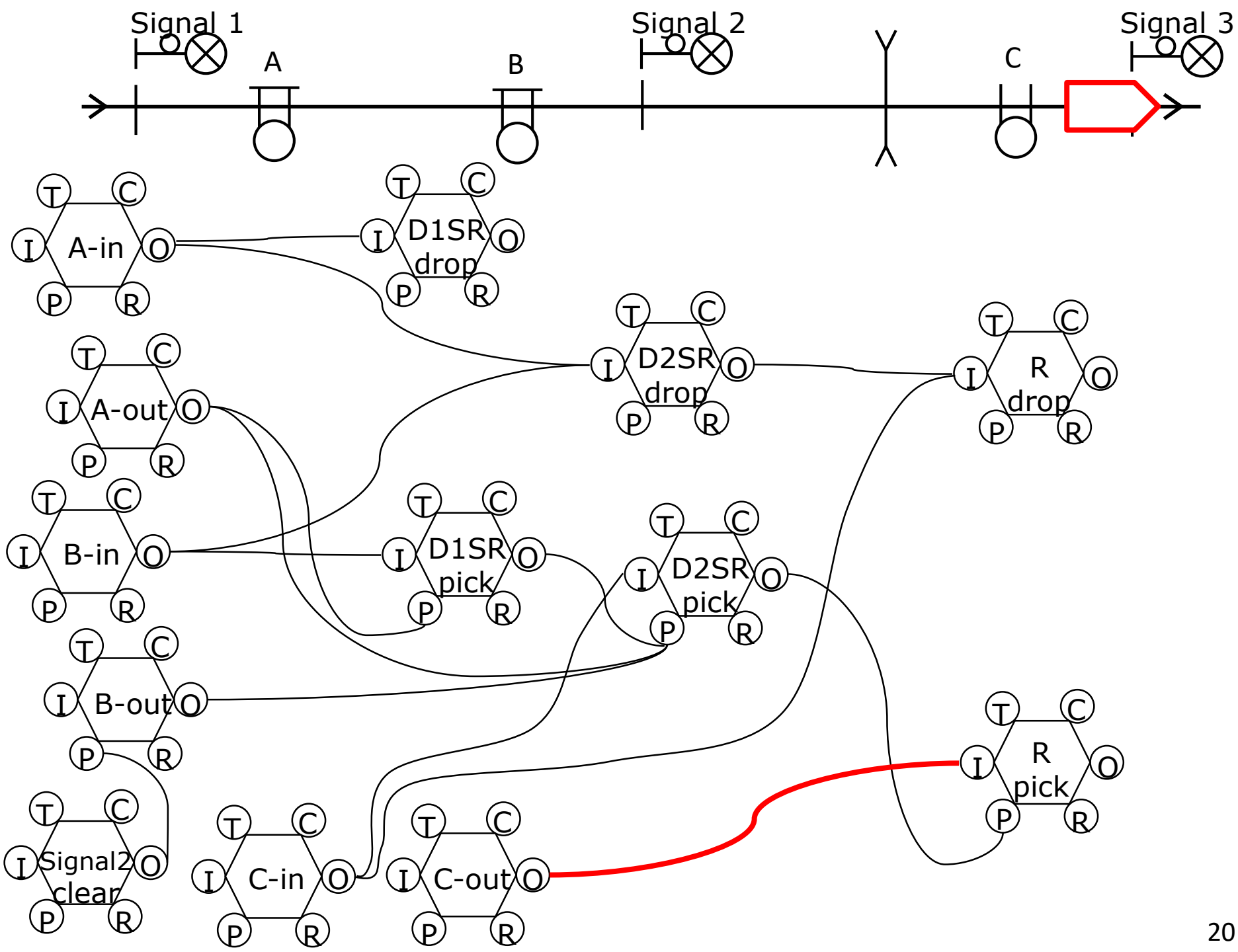

# FRAM model of the analyzed logic

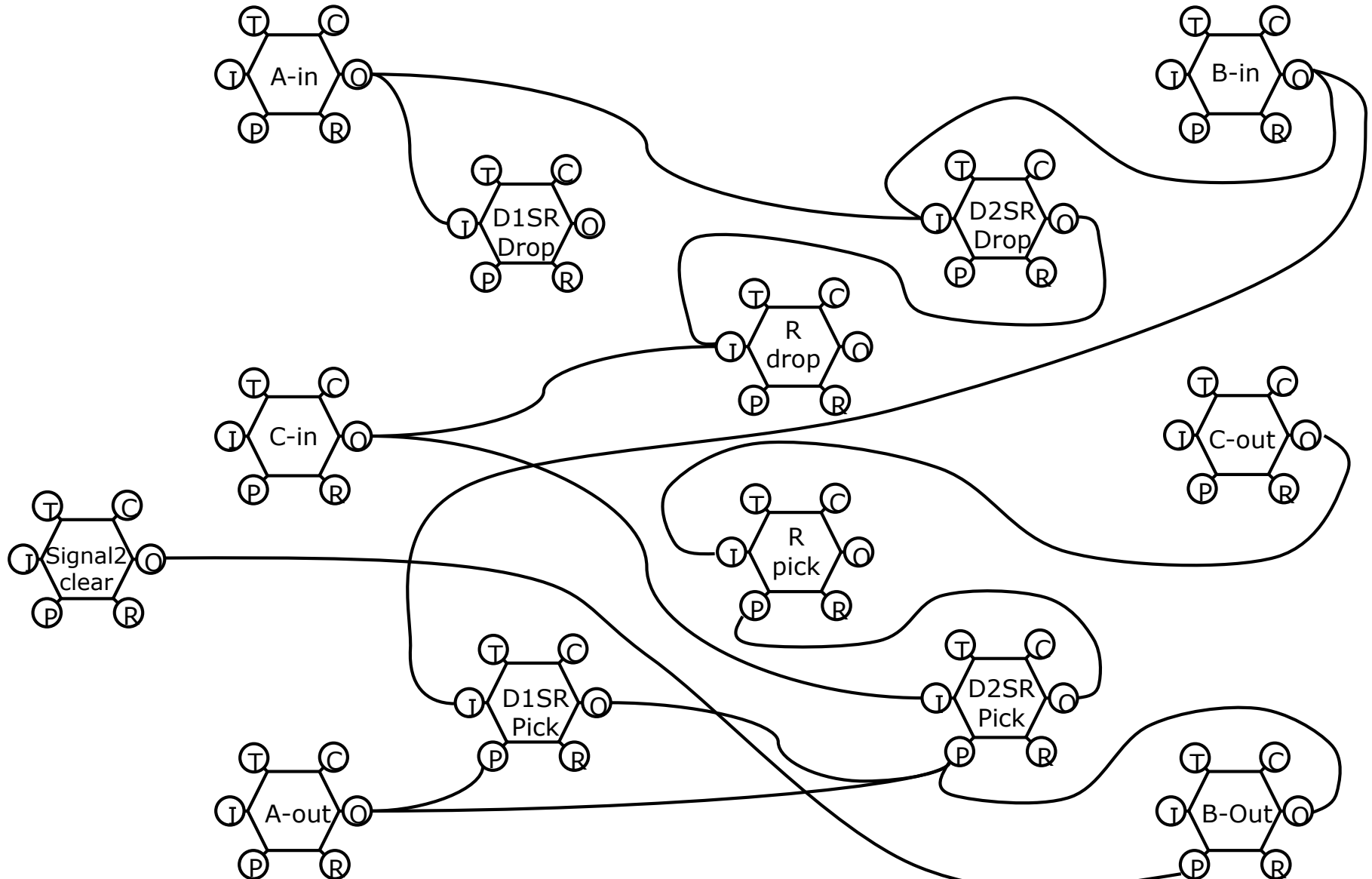

## (1) Layered structure

- Transmission of information to the neighboring upper layer
- Common logic format among different logics of LCs

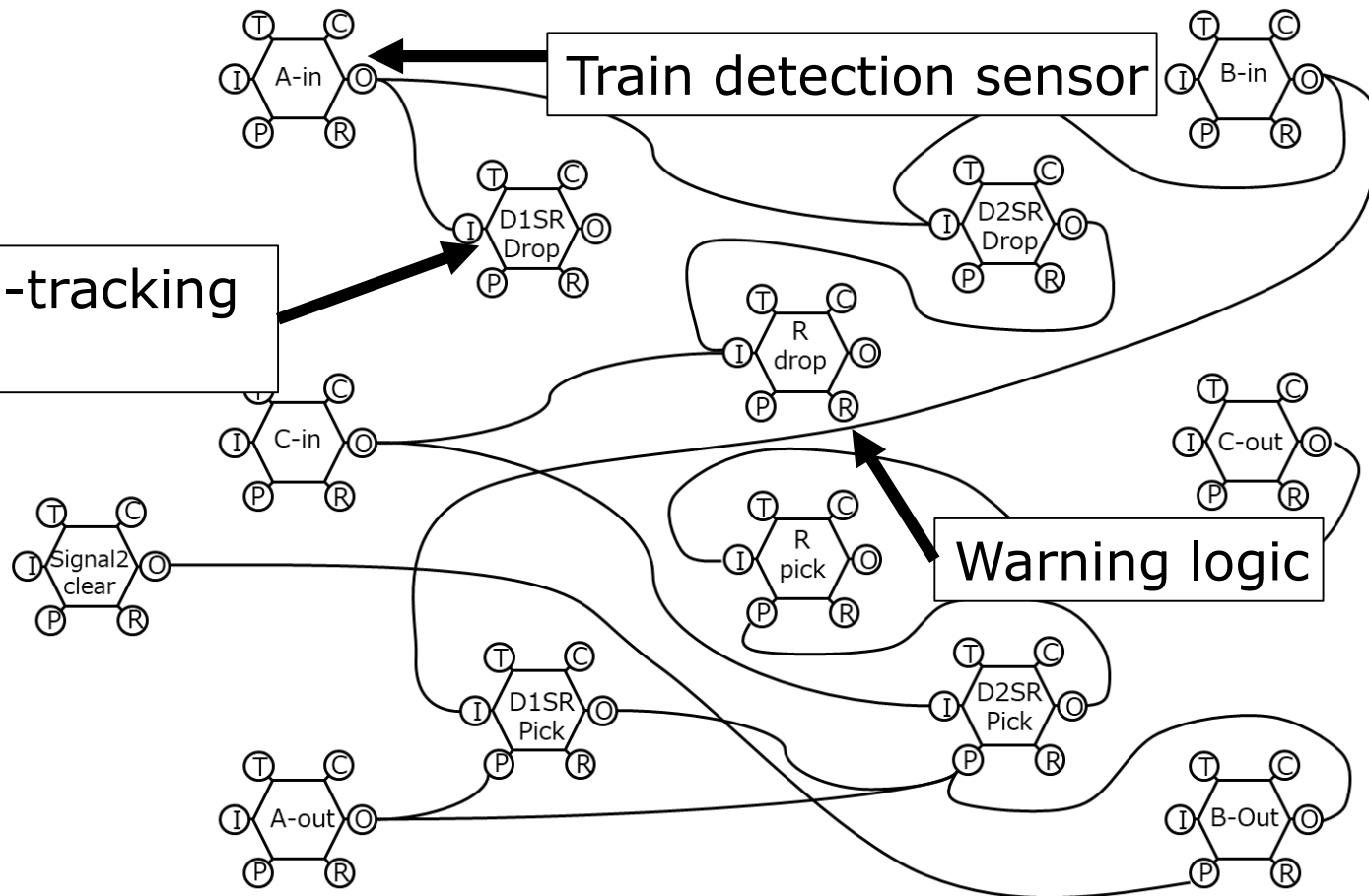

# Extraction of design guidelines

## (1) Layered structure

- Transmission of information to the neighboring upper layer
- Common logic format among different logics of LCs

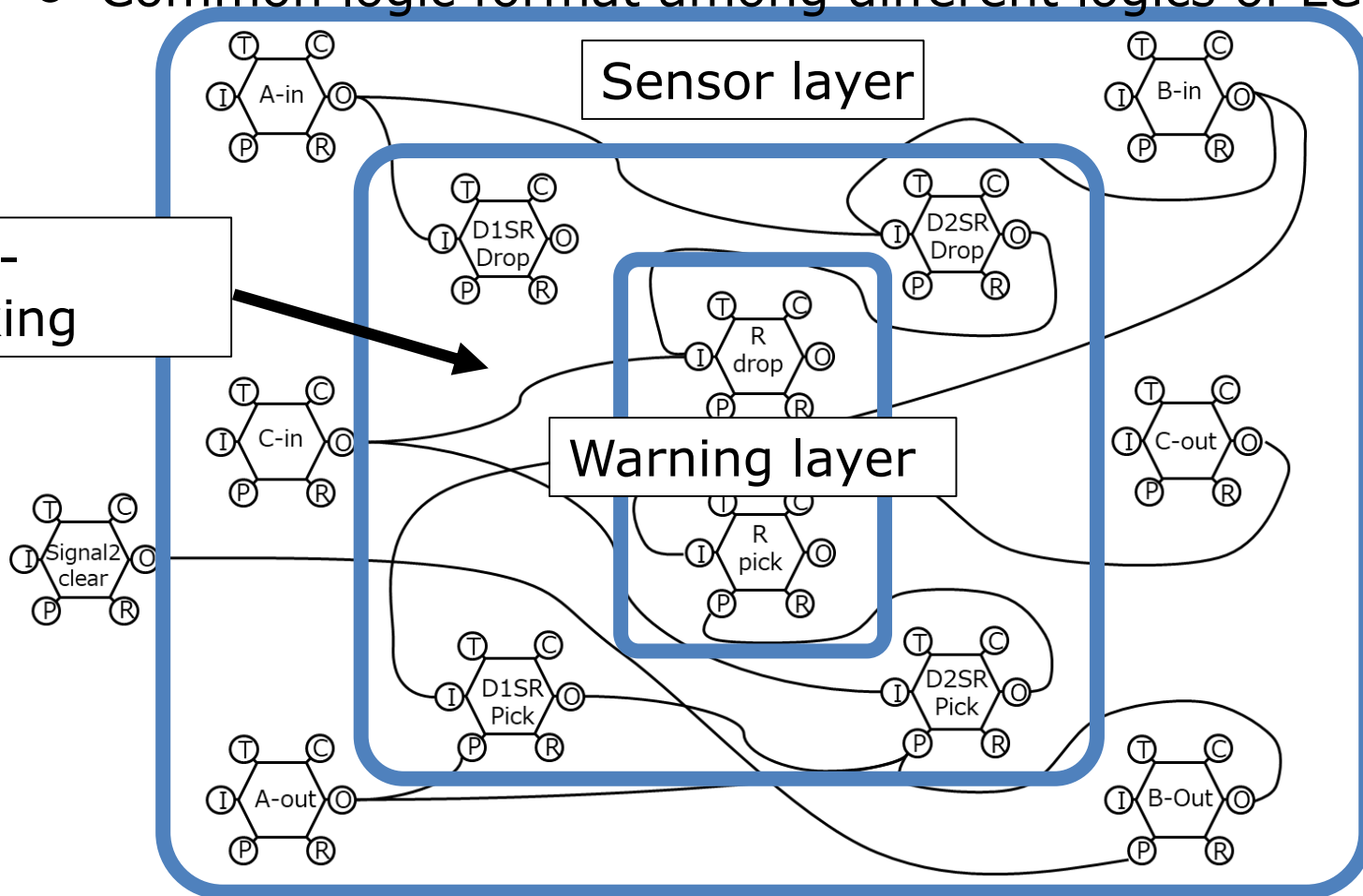

# Extraction of design guidelines

## (2) Start warning with one information

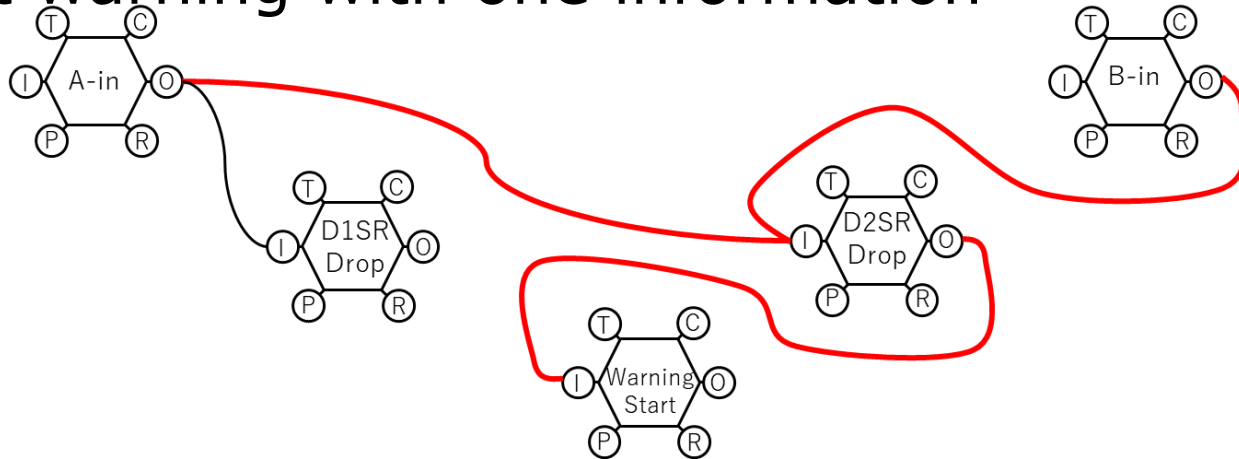

## (3) Stop warning with accumulation of information

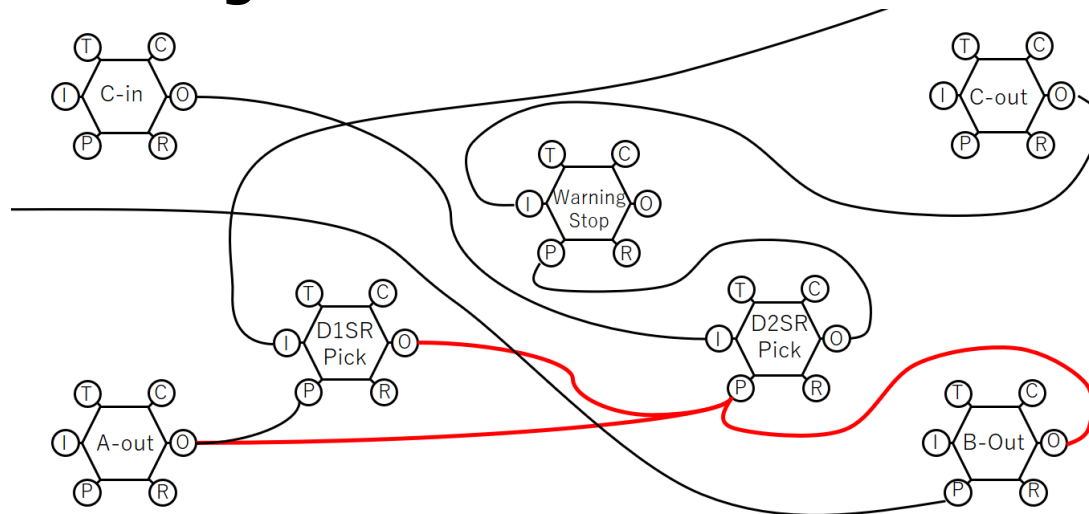

# Evaluation of the extracted guidelines by applying FRAM to an operating LC logic

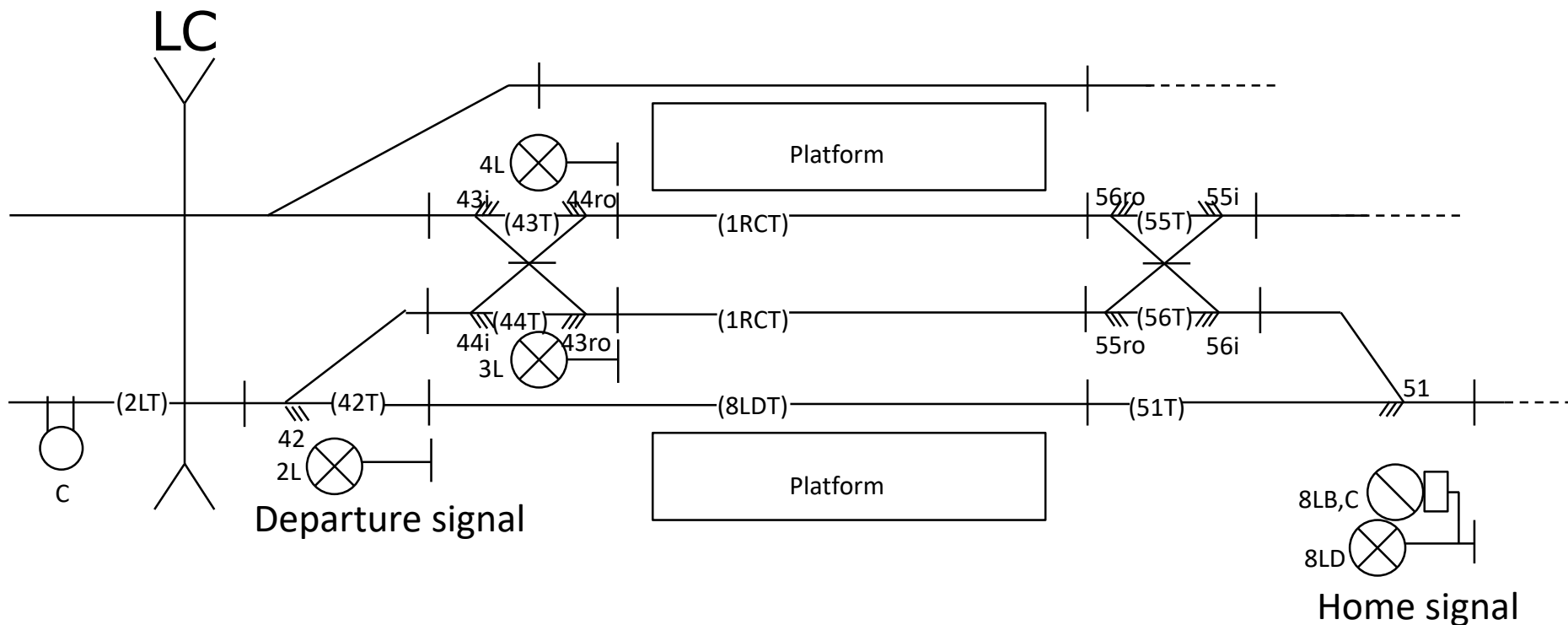

Facility layout of the examined LC and station

# Evaluation of the extracted guidelines by applying FRAM to an operating LC logic

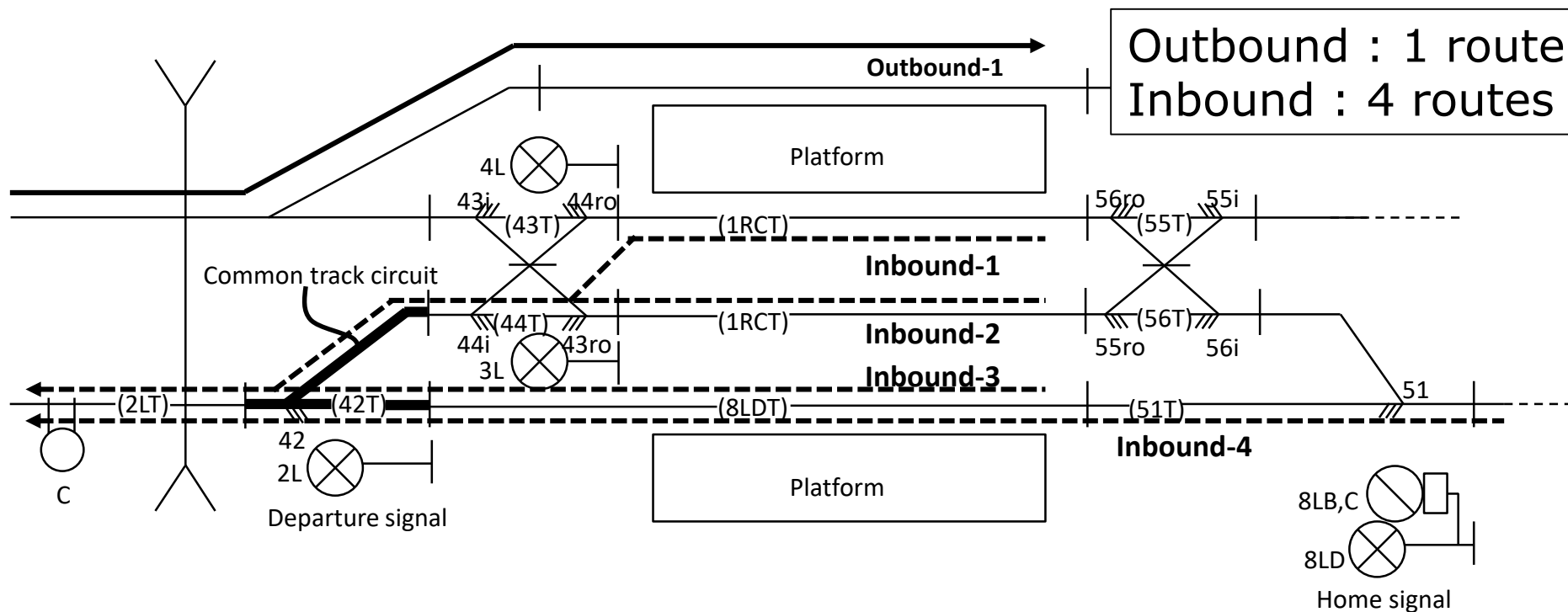

Facility layout of the analyzed LC and station

# FRAM model of the LC logic

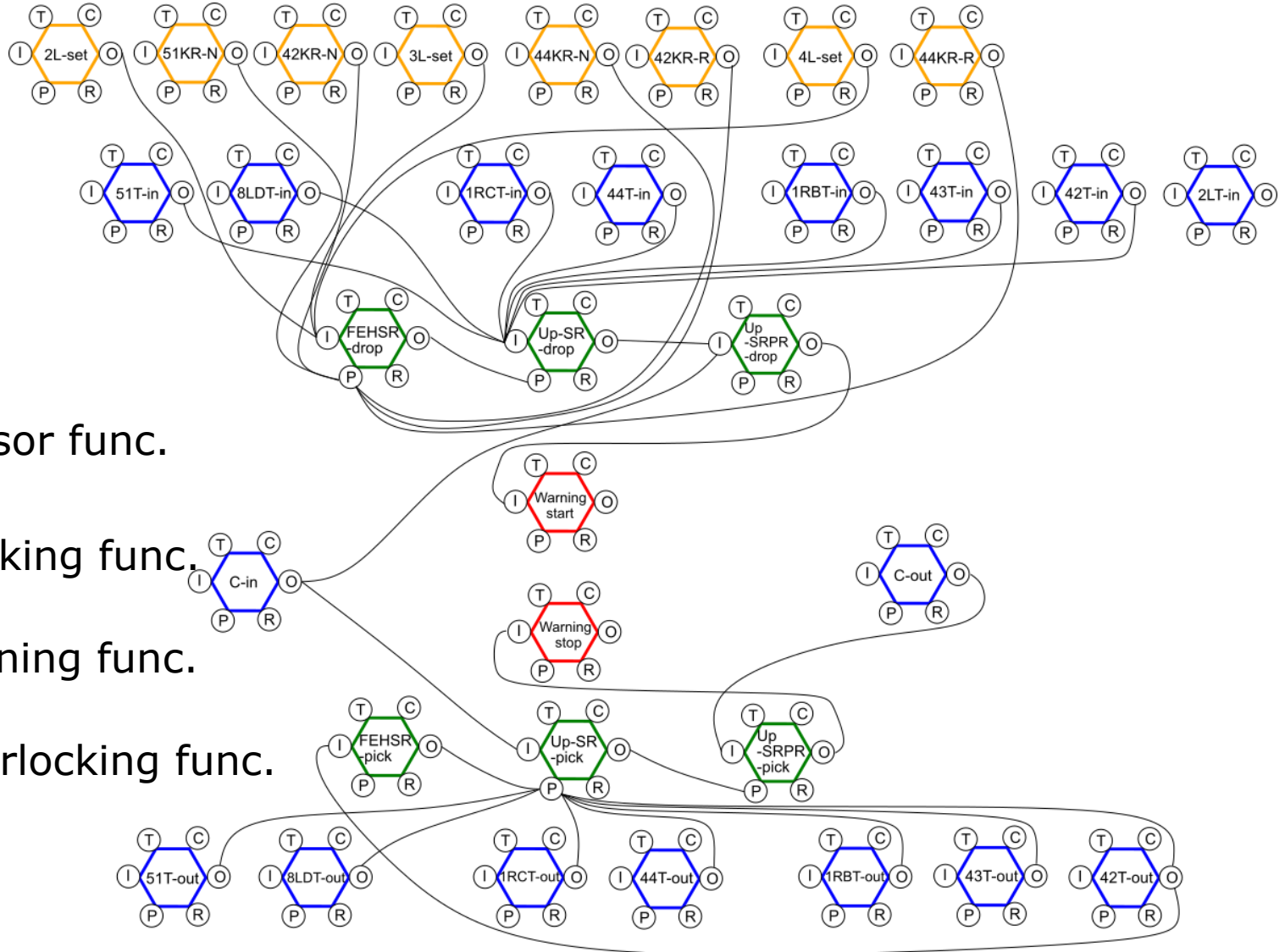

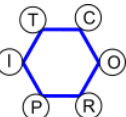
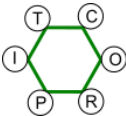
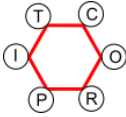
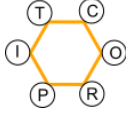
-  : sensor func.
-  : tracking func.
-  : warning func.
-  : interlocking func.

# (1) Layered structure

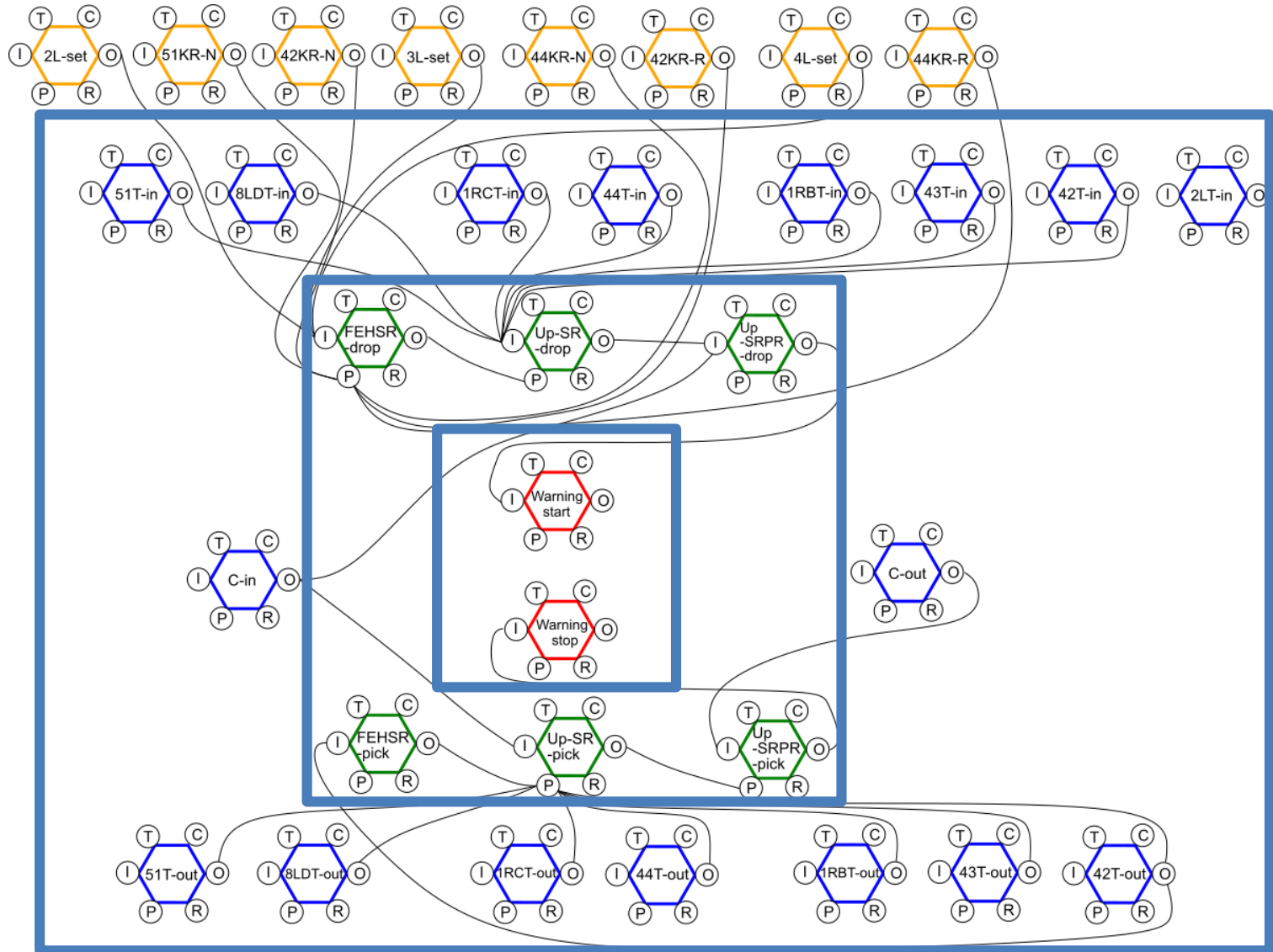

# (2) Start warning with one information

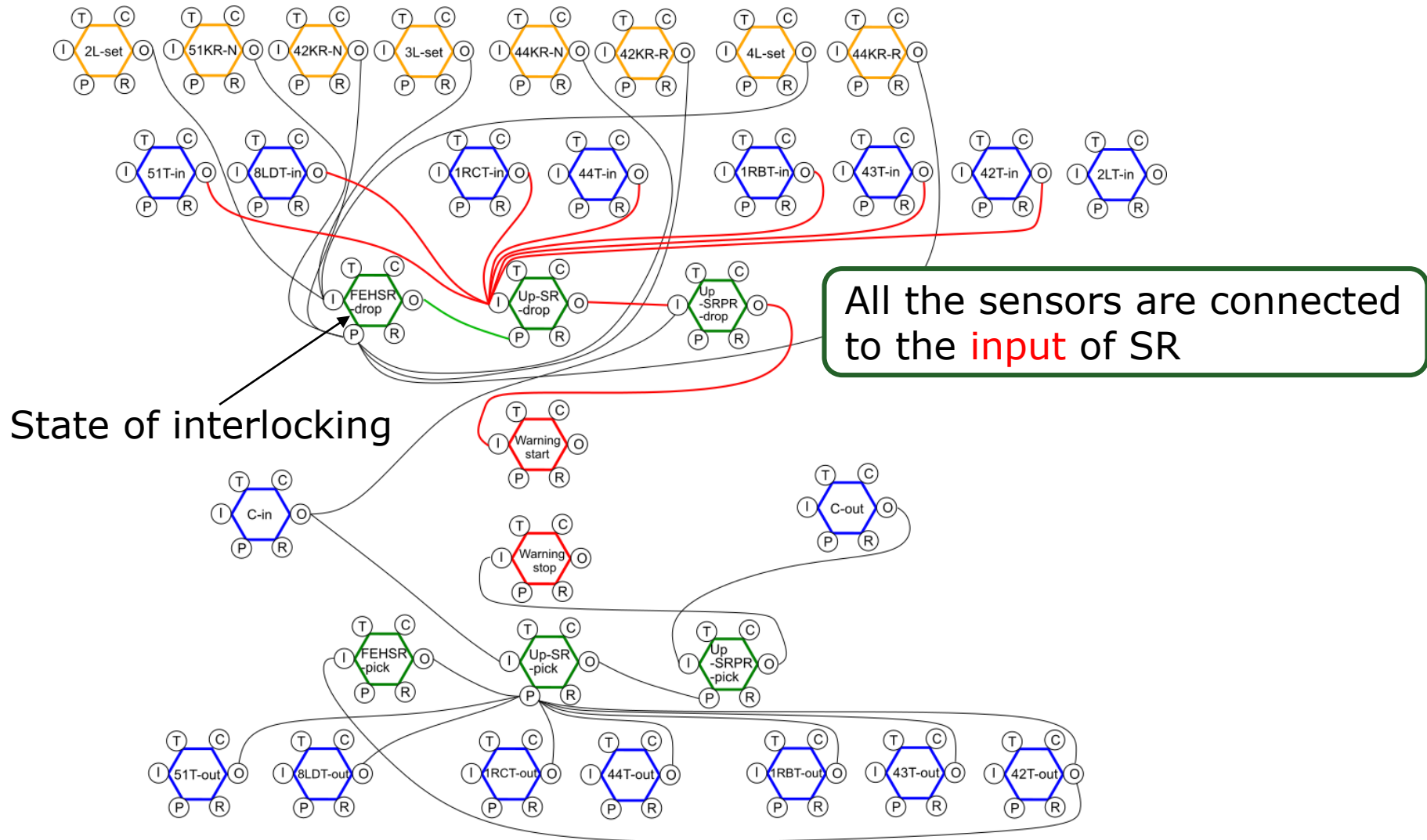

# (3) Stop warning with accumulation of information

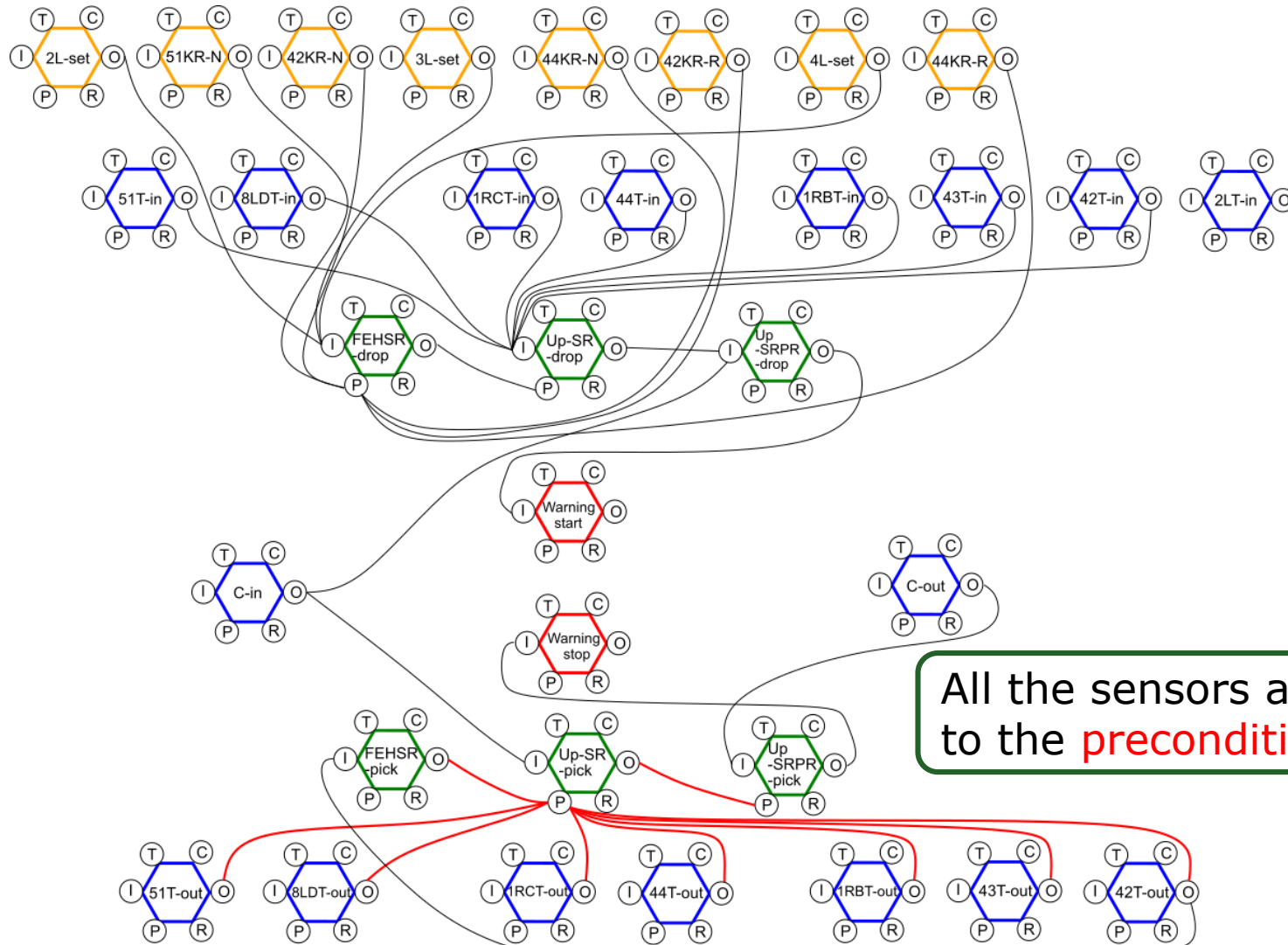

- Safety analysis method, FRAM was applied to standardized relay logic in JRE.
- Guidelines, which are natural for signalling engineers but not documented were extracted and observed in the operating logic
- We confirmed that FRAM offers a different perspective and is useful to analyze operating systems.