

Obstacle Detector for Level Crossing using Infrared Camera and Image Processing

Ryuta Nakasone, Researcher, Railway Technical Research Institute

Hiroki Mukojima, Researcher, Railway Technical Research Institute

Nozomi Nagamine, Senior Researcher, Railway Technical Research Institute

SUMMARY

Level crossings, being the intersection between railway and road traffic, have a potential risk of accidents to railway operation. In Japan, there are around 33,000 level crossings and over 90% of them are equipped with automatic barriers. Despite of all the efforts made by national and local governments and railway operators, every year more than 200 people are injured due to accidents inside level crossings. In order to detect pedestrians trapped inside level crossings, we propose a new Obstacle Detector (OD) using infrared camera and image processing algorithm.

Far-infrared camera is used as the sensor to acquire image of the crossing and to detect targets irrespective of their height. By applying far-infrared image, the device has features missing in the conventional devices, such as excellent resistance against weather and sunlight conditions, and does not require illumination. Obstacle detection (OD) is performed by image processing technique, using a combination of background subtraction and statistical filtering.

Evaluation result of the proposed method shows no False Negative output as a system and we have found that by applying filtering methods, probability of false operation of the OD can be reduced more than 10 times, which leads to stable operation.

1 INTRODUCTION

Over the past 10 years, number of level crossings throughout Japan have decreased by 4%, resulting to 16% decline in accident rate. In the recent years, installation of emergency push buttons have started as an act to reduce pedestrian accidents. However, the number of casualties from the accidents has shown little change, adding up to 200 casualties every year [1]. Number of accidents from year 2000 to 2017 are shown in Fig. 1.

Looking inside the accidents occurred throughout 2018, 35% of the collisions were against vehicles larger than cars, and the rest were against smaller obstacles such as motorcycles and pedestrians. Only 30% of the causes of the accidents were by mechanical malfunction of the objects, main causes of accidents came from inappropriate crossing just before trains were passing by. As a background to this situation, level crossings with high traffic volume are highly recommend to be equipped with Obstacle Detector (OD) in order to detect objects larger than normal sized cars stranded inside.

In order to detect pedestrians being trapped inside level crossings, we propose a new OD using infrared camera and image processing. Until 2018, we have been working on methods using Convolutional Neural Network (CNN) and machine learning, but due to problems for making learning data and other matters, we have renovated the sensor and detection method. In this paper we will introduce the concept of the system and detection methods, in addition to test results from real field environment.

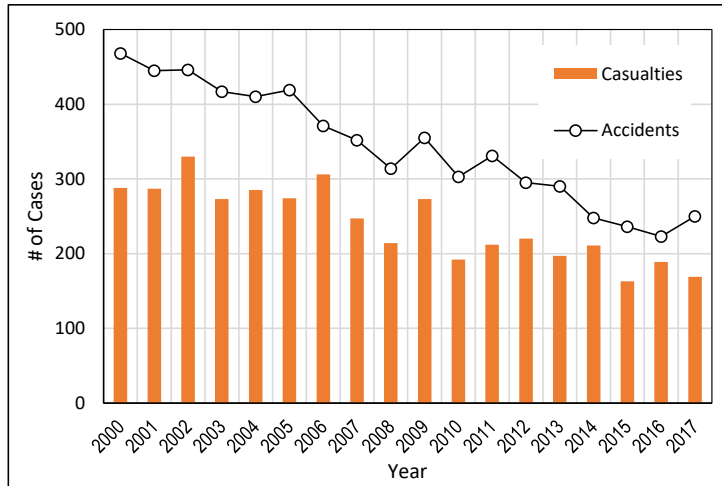

Figure 1: Level Crossing Accidents

2 OBSTACLE DETECTION TYPES

2.1 Conventional ODs

The most common ODs in Japan comprise of optical laser sensor with closed loop control [2]. The device emits a near-infrared laser beam across the level crossing, parallel to the rail, constructing a loop between the transponder and the receiver. The break of the loop indicates either obstacles inside the crossing or a system malfunction. It is a simple and robust way to detect large obstacles inside the level crossing but they have a very limited sensing range, only a single line between a source of light and a detector. Also, large scale construction is required at an installation and regular maintenance after the installation are becoming a large burden on railway operators. Nowadays, ODs using two dimensional and three dimensional range sensors have been introduced [3, 4], using millimetre wavelength radio waves or laser radar techniques. However, these devices are focused on the detection of vehicles and the detection performance of obstacles close to the road surface is tend to be unstable. In order to improve the detection performance, and to detect pedestrians being in potential dangerous situation, such as, people falling to the ground inside the level crossing, we propose a method using infrared camera.

2.2 Proposed method

We are working on the development of a pedestrian detection system using far-infrared camera and image processing. By using the image sensor, we are able to obtain information of the obstacles regardless of their height. The outline of the system and the device configuration is shown in Fig. 2. In the current device plan, the processing unit is installed inside an instrument box by the level crossing. Only a camera is needed to be installed outside of the box, 5 to 10 meters from the crossing at a height of 4 to 5 meters, with an Ethernet cable connecting the two equipment. Obtained image from the camera is stored inside the device for a period of time, which can be used for clear understanding of the level crossing conditions in case of an accident.

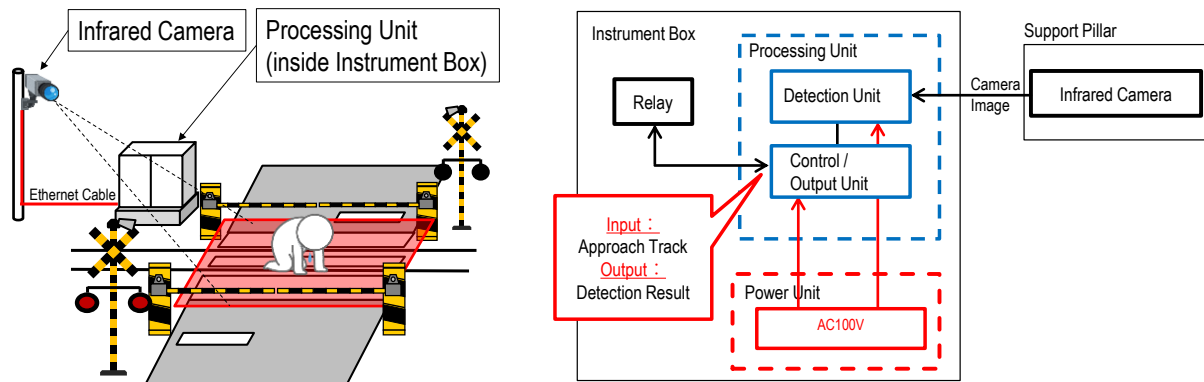

Figure 2: System Outline and Configuration

2.2.1 Far-infrared imaging

The camera outputs to the processing unit, absolute temperature of objects inside the Field of View (FoV) converting into an image of 480 by 620 pixel, sampled using 14 bit depth information. The camera converts temperature information to a greyscale image, where difference of temperature is represented by difference of brightness, the high temperature areas form a bright image and low temperature areas into darker image. Unlike normal cameras using visible lights, the camera captures infrared radiation from objects caused by black-body radiation, in wavelengths 7 to 14 μm .

Advantages of using infrared images include high noise tolerance against weather conditions and shadows from moving objects, respectively, compared to visible light. Also, the image can be obtained in total darkness regardless of ambient light conditions, thus eliminating the need for external lighting equipment.

2.2.2 Detection method

Far-infrared image of the level crossing is inputted to the detection process as a continual image sequence of 480 by 620 pixel per frame. The image is down converted into 8 bit depths gradation per pixel, to represent relative temperature of the FoV.

The processing algorithm generates a background image, based on the input image from past 20 frames, to detect the differences between the generated background image and the current frame as candidates. Simple subtraction of the two images will most likely lead to multiple False Positive detection due to spatial and heat noise, therefore, the proposed method applies feature extraction [5] to the images before performing detection and classification. A labelling process, based on statistics of the human body size and appearance onto the screen image, is applied to each obstacle candidate to detect the presence of a pedestrian inside the level crossing. As the background is made from the past 20 frames, if obstacles stay inside the detection area for a while, the obstacles may become included into the background. To avoid this situation, a measure is applied to remember the foreground until the target starts moving again. Finally, with respect to the detection results, obstacle candidates are determined whether they are inside the detection area, an arbitrary area set by the user. In order to enable post analysis, x and y coordinates of the bounding box of each obstacle is outputted, as well as width, height and labelling result. Figure 3 shows the framework of the proposed detection method.

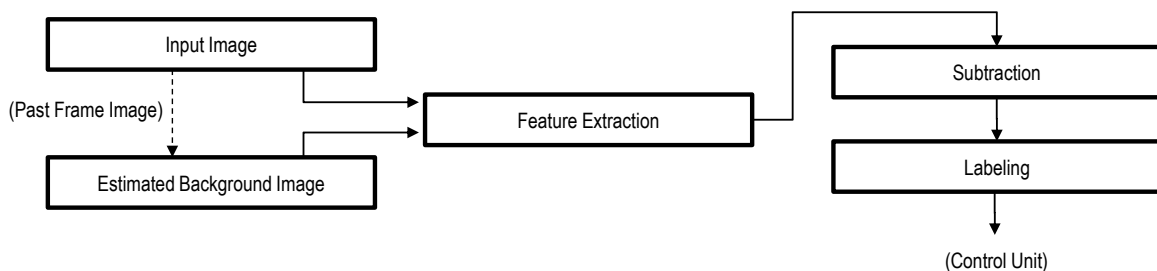

Figure 3: Framework of Detection Method

2.3 Equations and Special Notation

In order to reduce output chattering effect due to False Positive (FP) detection, and to minimize the non-detection state due to False Negative (FN) results, the proposed system has a control unit in-between the detection unit and signal output section. The detection unit outputs detection results as, “1” for detection and “0” for non-detection state, for each single frame output from the camera device. The control unit comprehensively judges the state of the level crossing from detection results of past and current frames, and outputs a warning signal in case of pedestrians trapped inside the level crossing.

Relationship between the true state of the level crossing and output of detection unit is shown in Fig. 4. When the detection unit outputs “1”, detection of obstacle inside detection area, the control unit keeps the state to “1” for a period of time after the first output regardless of each single output of “0”. After this measure, whenever the detection state is at “1”, a count sequence starts inside the control unit to judge the continuity of the real state.

		True state of level crossing	
		Obstacle inside	Obstacle free state
Detection output	1	True Positive output (TP)	False Positive output (FP)
	0	False Negative output (FN)	True Negative output (TN)

Figure 4: Relationship between Output and True State

Finally when the conditions are met, when the continuity of the count exceeds the initial setting value, the control unit triggers a signal to output section, stopping train operation via warning signals.

Detection program will output a value for each frame from the camera, “1” if it detects an obstacle inside and “0” for non-detection. When output value of the detection program is “1”, control unit will keep the state to “1” for the next N frames. If there are no detection output for the next N frames, the control unit will cancel the state and return it to “0”. If there is an output of “1” within N frames, control unit will keep the state for the next N frames for each detection output. After the control units function to hold the state, if the state is “1”, a count sequence starts inside the control unit to check the continuity of detection output. Finally, when the count continues and exceeds the value of M, the system will output a signal to stop train operation. The meaning of holding the state to “1” is to reduce the possibility of non-detection, since it is more dangerous for the system to miss-output than to false-output. Simultaneously, by looking at the continuance state of the output, we are able to reduce false output caused by random noise effects. Overall, this function prevents miss-detection caused by continual FN output that are shorter than N. It is necessary the value of M is bigger than N for this to work. In general, reducing the value N or increasing the value M will result to “good performance” but reduction of N leads to increase of miss-output, and increase of M will affect the time it takes to output signal from first detection.

2.3.1 FN leading to miss-detection

The following example shows different result with and without the control unit. True state of the level crossing is shown in Fig. 5(a) were the target entered the area at t=5 and stayed inside the detection area. If the detection program successfully detected the target, count sequence will start from t=5 and output will be made after exceeding the setting value M. In a case were FN output occurs randomly, at t=5 to 7 and t=11 to 12 shown in Fig 5(b), count sequence will be reset at t=11 and not being able to output detection signal without the control unit. When the output is kept to state “1”, continuity of the count sequence will be intact thus leading to correct output by the system. Holding the output state to “1” will prevent non-detection state of the detection system caused by random FN results. However, this measure may lead to false operation due to FP results, described in next paragraph.

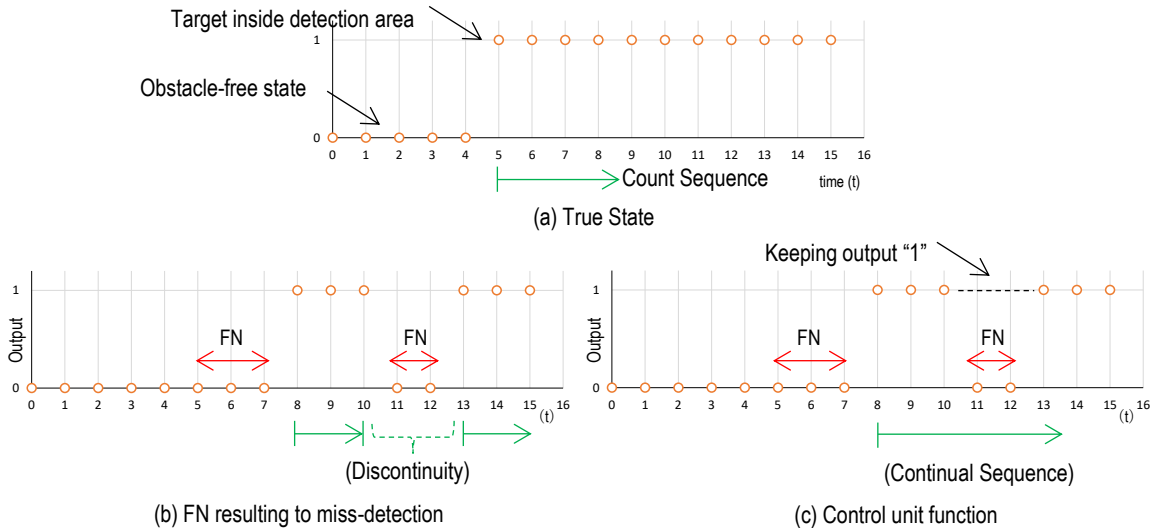

Figure 5: Function of Control Unit

2.3.2 FP leading to false function

This section describes the possibility of false output from proposed system due to FP result of detection program using specific setting value.

Effects of FP detection are different based on the true state of the level crossing. In this case, false detection with obstacle inside the crossing for true state is considered. As an example, the true state of the level crossing is shown in Fig 5(a). In this situations the following two types of scenario may affect the behavior of the system. A) FP occurs right before a target enters the detection area; count sequence starts before target entering the area, triggering the system to output signal faster than the intended timing. B) FP occurs after the target exits detection area; count sequence continues without target inside the level crossing, triggering the system to output signal without target inside the crossing. The fundamental objective of the OD is to stop train operation, therefore false function of the device may cause a problem to stable train operation. Still, the two scenarios are disregarded because they will only pose a small effect to the operation since they will only continue for a small period of time, only for a second or so.

Next, false detection in an obstacle-free state is considered. The true state of the level crossing is shown in Fig. 6(a) and output of the detection program is shown in Fig 6(b). In this case, when a FP occurs, it may trigger a false output from the system effecting the train operation. When FP occurs several times intermittently in a short time span, the first FP result triggers the count sequence to start, and because the detection output "1" is held on by the control unit, continuity of the count may exceed the setting value, resulting a false output of the system.

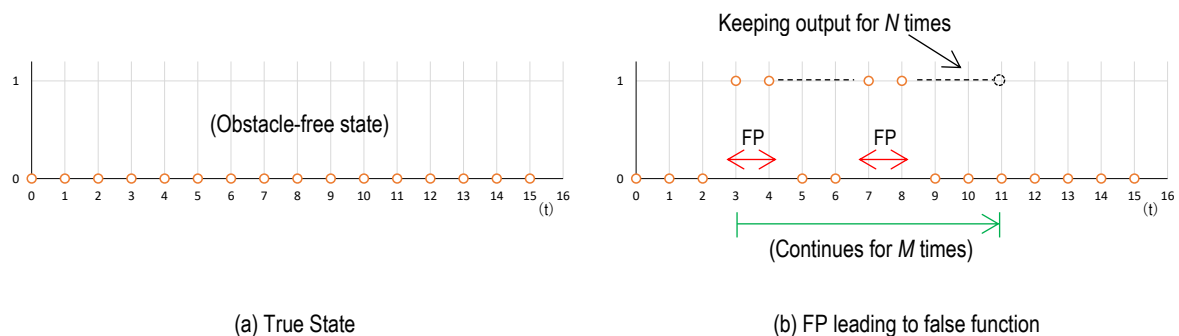

Figure 6: False Function

From here forward, it states the possibility of false output of the proposed system using practical value of $N=7$ and $M=10$. After FP occurs at $t=0$, for the system to *NOT* false output, the interval of FP must exceed $N+1$ times, in this case 8 or 9 times, which there are only three patterns as follows:

- 100 000 000 0
- 100 000 000 1
- 110 000 000 0

Were the result of detection program is shown in “1” as detection and “0” as non-detection, time sequence from left to right. When the possibility of FP is result of truly random noise, the possibility of false output $P(fo)$ is shown below:

$$P(fo) = 1 - ((1 - P(fp))^9 + (1 - P(fp))^8 P(fp)) \times 2 \quad (1)$$

Where, $P(fp)$ is probability rate of FP output. For example, when $P(fp)$ is at 1%, $P(fo)$ is 6.8% respectively, the possibility of FP to occur and at arbitrary timing t , and for it to trigger false output is calculated by $P(fp)$ multiplied by $P(fo)$ resulting to 0.068%. As shown here, by applying the control unit function, we have succeeded in decreasing the possibility of false output whilst taking account of preventing miss-outputs.

2.4 Evaluation

2.4.1 Evaluation scale

Performance of the proposed method depends on detecting objects accurately, with minimised false results. Normally, detection rates and false detection rates are evaluated for performance, however, results from pervious section show system performance depends on FP rate and continuity of FN state exceeding value N . From this, accuracy of the proposed detection method was evaluated using the following criteria;

- False Detection Rate : Number of frames with FP / Number of frames used for evaluation
- Continuity of FN output : Maximum number of continuous frames of FN results.

Reference data was made by manually annotating a bounding box around targets entering the detection area. False Detection is defined as output results which do not overlap the area of manual bounding boxes regardless of the true state of the level crossing. Definition of non-detection is where a target is actually inside the area but there are no outputs overlapping the target. When there are multiple outputs in one image, one output overlapping the reference bounding box and another in a different region, it counts as false detection but not a non-detection event.

2.4.2 Evaluation environments

Evaluation of the proposed detection method was conducted using recorded image data from two environments, a level crossing inside the premises of Railway Technical Research Institute (RTRI), Tokyo, and an actual level crossing operating in Hokkaido. The objective of the different environment tests is to evaluate performance under difficult conditions for 1) practical image processing 2) conventional OD operation. Data from RTRI was recorded in the rain where temperature difference between the foreground and background is relatively small and the obtained image is vague even to the human eye. Data from Hokkaido was recorded under freezing temperatures with significant amount of snow covering the detection area, conditions where conventional ODs would be difficult to operate. A camera was installed at a position, 5 to 10m from the crossing, strapped on a pole at 4 to 5m height, recording the image at 10 frames per second. The camera was set to a position, parallel to the track, and a certain angle where the appearance of the automatic rod inside the image is minimized. Figure 7 shows the test environment at Tokyo and Fig. 8 shows a view from the camera at Hokkaido.

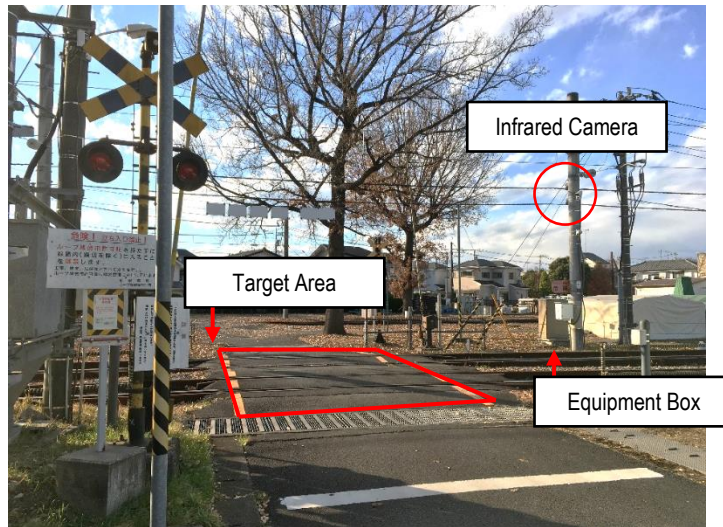

Figure 7: Test Environment at RTRI



Figure 8: View from the Camera at Hokkaido

2.4.3 Results

The values following are the detection result directly from detection program, without the function of the control unit mentioned in 2.3.4.

In the experiment at Tokyo, a total of 20,968 frames were obtained including 6,482 frames with detection targets inside the level crossing. Outside temperature was 16.2 °C and constantly raining with average surface temperature of the background at 22°C and foreground at 23°C. During the experiment, candidates either wore raincoats or used umbrellas with transparent and coloured surfaces. Example of detection result is shown in Fig. 9. As a result, there were zero FN detection and 17 FP resulting to False Detection Rate of 0.08%; the main reason of FP was sudden change in the brightness due to automatic camera calibration. The FP outputs were non-frequent and sporadic, negligible by the total system.

As for the experiment at Hokkaido, a total of 50,000 frames were obtained including 2,496 frames with detection targets, pedestrians passing through the level crossing. Outside temperature was -5.0°C and mildly snowing with 20cm of fallen snow on the level crossing. There were zero FN detection and 1341 FP, False Detection Rate of 2.7%, The main and critical cause of the FP was tracks from tires and exhaust fumes warming up the ground after a vehicle passing the level crossing; problematic because the tracks are results of physical phenomena and appear on the image distinctively, shown in Fig. 10. FP results from the tracks continue for up to 15 seconds which pose a problem even with the control unit, counter-measures are assessed and considered but unimplemented at this

time. Although proposed systems objective and evaluation is aimed on pedestrians, we state that there were 45 vehicles passing inside the recorded footage and were able to detect each vehicle as they passed by, not included in the initial 2,496 frames.

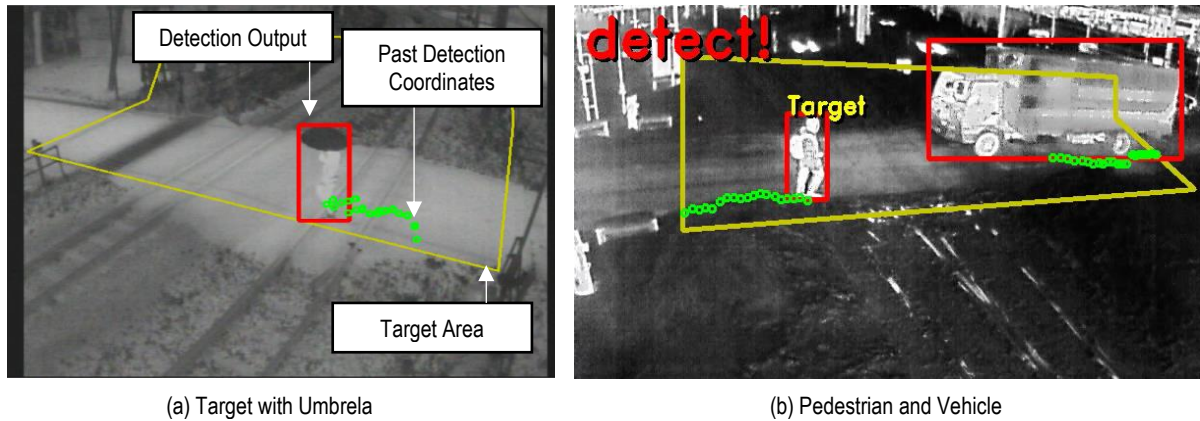

Figure 9: Example of Detection Result

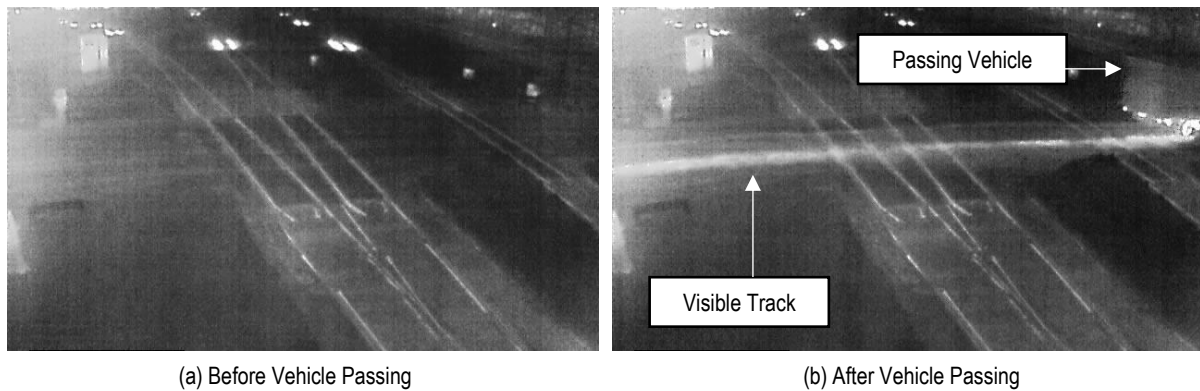

Figure 10: Tracks Appearing in Image

3 CONCLUSION

In this paper we have proposed an obstacle detection method aimed on detecting pedestrians inside level crossings. Compared to conventional ODs, the proposed system uses far-infrared camera and image processing to detect fallen targets near the surface of the ground efficiently.

We have shown that minimising the effect of false detection from the detection program and miss-detection of the system is possible by applying function of the proposed control unit.

Basic evaluation test were conducted which show the possibility of the proposed method under practical weather conditions, with zero false negative results, though additional features are needed for applying to heavy snow regions. Also, conditions of the evaluation tests were limited and additional analysis is needed for further research.

4 REFERENCES

1. Ministry of Land, Infrastructure, Transport and Tourism. *Annual Report on Safety of Railway Track (Heisei 29)*. 2018.
2. Junro S, et al. Photo-Electronic Obstruction Detector for Railway Crossing. Nippon Signal, 1978.
3. Satoshi N, et al. Millimeterwave Railroad Crossing Obstacle Detection Device. *Railway & electrical engineering*. 2011.

4. Yutaka H, et al. 3-D Laser Radar Railroad Crossing Obstacle Detection System. IHI Engineering Review. 2008.
5. Lili G, et al. *Background Subtraction using Local SVD Binary Pattern*. IEEE, 2016.